



**FITTING INSTRUCTIONS FOR LP0357**  
**LICENCE PLATE BRACKET**



**THIS KIT CONTAINS THE ITEMS PICTURED AND LABELLED OVER PAGE.**

SOME PARTS MAY BE SHOWN FOR CLARITY OF INSTRUCTIONS ONLY.

DO NOT PROCEED UNTIL YOU ARE SURE ALL PARTS ARE PRESENT.

**PLEASE READ ALL INSTRUCTIONS BEFORE PROCEEDING.**

**IF IN ANY DOUBT WHEN FITTING OUR PRODUCTS, CONSULT ONE OF OUR DEALERS  
OR HAVE FITTED BY A QUALIFIED TECHNICIAN.**

PLEASE NOTE THAT THE WAY THE KIT IS PACKED DOES NOT NECESSARILY REPRESENT THE WAY OF  
MOUNTING TO THE BIKE.

IN THE EVENT OF RUBBER WASHERS BEING USED TO HOLD COMPONENTS ONTO BOLTS,  
THESE RUBBER WASHERS CAN BE THROWN AWAY.

**DIGITAL COPIES OF THESE INSTRUCTIONS ARE AVAILABLE FROM:**

[WWW.RG-RACING.COM](http://WWW.RG-RACING.COM)



<u>TOOLS REQUIRED</u>	<u>GENERAL TORQUE SETTINGS</u>
<ul style="list-style-type: none"> <li>METRIC SOCKET AND WRENCH</li> </ul>	<p>M4 BOLT = 8Nm                      M5 BOLT = 12Nm                      M6 BOLT = 15Nm                      M8 BOLT = 20Nm                      M10 BOLT = 40Nm                      M12 BOLT = 40Nm</p>

**LEGEND**

ITEM NO.	DESCRIPTION	QTY
ITEM 1	TB0354 - LICENSE PLATE BRACKET	1
ITEM 2	M6 WASHER	4
ITEM 3	LA0002 - LICENSE PLATE ILLUMINATOR	1
ITEM 4	2.5mm CABLE TIES (NOT SHOWN)	5
ITEM 5	666-896-15 - 150mm LENGTH OF HEAT SHRINK (NOT SHOWN)	1
ITEM 6	REFL3 - REFLECTOR (NOT SHOWN)	1

**ASSEMBLY DIAGRAM**

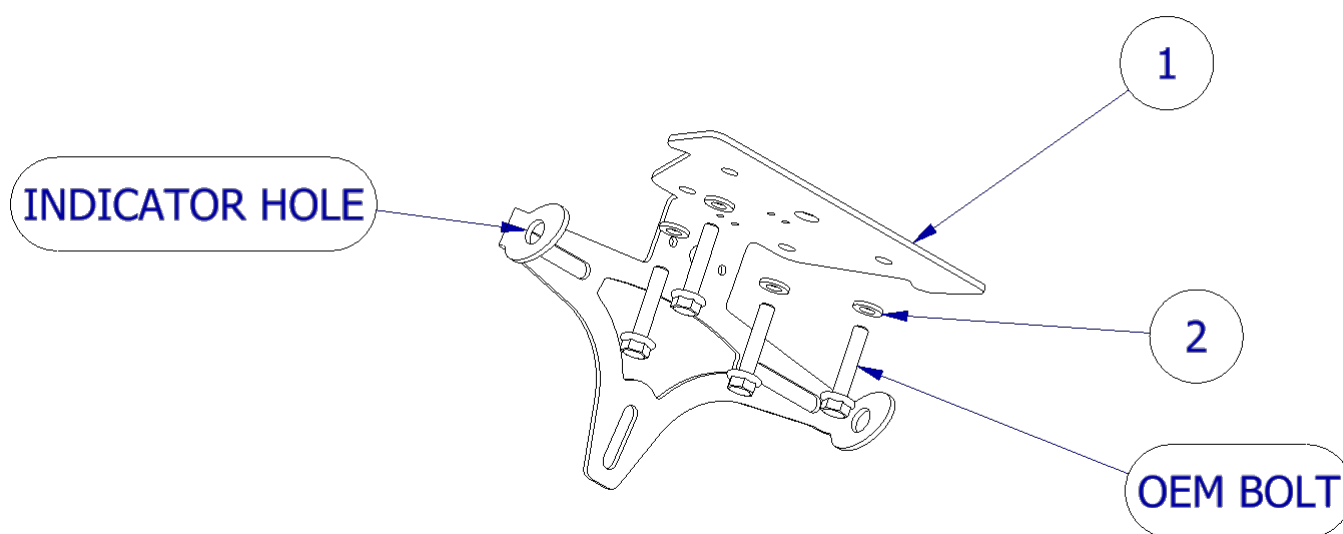

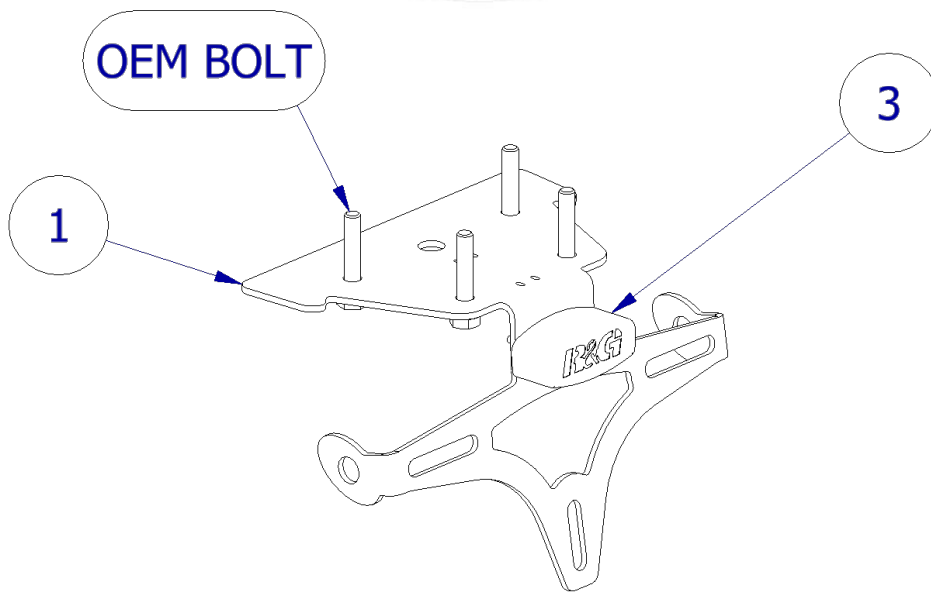

**FITTING PICTURES**



**Picture 1**

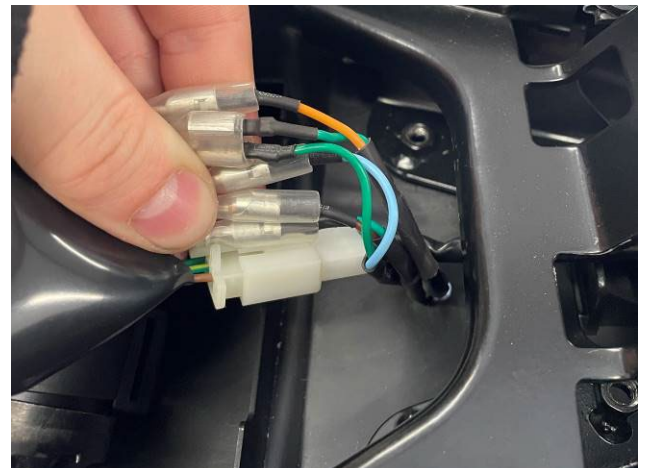

**Picture 2**



**Picture 3**



## **FITTING INSTRUCTIONS**

- Begin by removing the passenger seat using the key.
- Remove the bolts securing the OEM tail unit to the bike as shown in **Picture 1**.
- Now, with the tail ready to be lifted away, disconnect the 6X bullet connectors highlighted in **Picture 2**.
- Keep the 4 x OEM bolts safely to one side which are used to mount the OEM license plate bracket to the bike.
- Thread the indicator cables along with the LA0002 cable through the corresponding holes in the tail tidy bracket and mount each using either the supplied (LA0002) or OEM (indicators) nuts.
- Protect the LA0002 wires by using the provided heat shrink (**ITEM 5**).
- Tidy up all cables using the provided cable ties (**ITEM 4**) and slotted holes provided in the license plate bracket & thread all cables through the centre clearance hole in the tail tidy bracket (as shown in **Picture 3**).
- Secure the R&G Tail Tidy to the bike using the OEM bolts and washers provided (**ITEM 2**) as shown in **ASSEMBLY DIAGRAM**.
- Check that the indicators and license plate illuminator are wired correctly and operating as they should before re-installing the seat.

**IMPORTANT: IF FITTING A FULL-SIZE LICENCE PLATE AND PLACING IT FAR DOWN ON THE LICENCE PLATE HANGER, THERE IS A SMALL CHANCE OF THE LICENCE PLATE HITTING THE BACK WHEEL UNDER HEAVY LOAD AND OVER LARGE BUMPS IN THE ROAD. IT IS YOUR RESPONSIBILITY TO CHECK FOR THIS POSSIBILITY AND TAKE AVOIDING ACTION. FAILURE TO CHECK THIS COULD RESULT IN SERIOUS INJURY.**

**See more R&G products for your Motorcycle in the link below:**  
[R&G Racing | Cleaning/Lubrication - Gleam range for All Vehicles \(rg-racing.com\)](http://www.rg-racing.com)

ISSUE 1 – 27/03/2023 - (MH)

### **CONSUMER NOTICE**

The catalogue description and any exhibition of samples are only broad indications of the Products and R&G may make design changes which do not diminish their performance or visual appeal and supplying them in such state shall conform to the order. The Buyer acknowledges no representation or warranty (other than as to title) has been given or will apply to the Products other than those in R&G's order or confirmation and the Buyer confirms it has chosen the Products as being of merchantable quality and suitable for its particular purposes. Where R&G fits the Products or undertakes other services it shall exercise reasonable skill and care and rectify any fault free of charge unless the workmanship has been disturbed. The Buyer is responsible for ensuring that the warranty on the motorcycle is not affected by the fitting of the Products. On return of any defective Products R&G shall at its option either supply a replacement or refund the purchase money but shall not be liable if the Products have been modified or used or maintained otherwise than in accordance with R&G's or manufacturer's instructions and good engineering practice or if the defect arises from accident or neglect. Other than identified above and subject to R&G not limiting its liability for causing death and personal injury, it shall not be liable for indirect or consequential loss and otherwise its liability shall be limited to the amounts paid by the Buyer for the Products or the fitting or service concerned. These terms do not affect the Buyer's statutory rights.

### **R&G RACING RETURNS POLICY (NON-FAULTY GOODS)**

Returns must be pre-authorized (if not pre-authorized the return will be rejected). Goods may only be returned direct to us if they were purchased direct from us (customer must prove if necessary). Otherwise to be returned to original vendor. Goods must be in re-sellable condition, in the opinion of R&G Racing. All returns are subject to a 25% restocking and handling fee (25% of the gross value exc. P&P – at the prevailing price at time of purchase). The customer must pay any and all carriage charges. No returns of discontinued products, unless within 14 days of purchase. This policy does not affect your statutory rights and does not refer to faulty goods.

R&G Racing

Unit 1, Shelley's Lane, East Worldham, Alton, Hampshire, GU34 3AQ

Tel: +44 (0)1420 89007 Fax: +44 (0)1420 87301 [www.rg-racing.com](http://www.rg-racing.com) Email: [info@rg-racing.com](mailto:info@rg-racing.com)



**NOTICE DE MONTAGE POUR LP0357**  
**SUPPORT DE PLAQUE**



**CE KIT CONTIENT LES ARTICLES ILLUSTRÉS ET ÉTIQUETÉS SUR LA PAGE.**

CERTAINES PARTIES PEUVENT ÊTRE PRÉSENTES UNIQUEMENT POUR LA CLARTÉ DES INSTRUCTIONS.

NE PAS PROCÉDER AU MONTAGE TANT QUE VOUS N'ÊTES PAS SÛR QUE TOUTES LES PIÈCES SOIENT PRÉSENTES.

**VEUILLEZ LIRE TOUTES LES INSTRUCTIONS AVANT DE CONTINUER.**

**EN CAS DE DOUTE LORS DU MONTAGE DE NOS PRODUITS, CONSULTEZ UN DE NOS REVENDUEURS OU FAITES APPEL À UN TECHNICIEN QUALIFIÉ.**

VEUILLEZ NOTER QUE LA FAÇON DONT LE KIT EST EMBALLÉ NE REPRÉSENTE PAS NECESSAIREMENT LA MANIÈRE DE LE MONTER SUR LA MOTO.

SI DES RONDELLES EN CAOUTCHOUC SONT UTILISÉES POUR MAINTENIR LES COMPOSANTS SUR LES BOULONS, ELLES PEUVENT ÊTRE JETÉES.

**NOTICE DISPONIBLE AU TÉLÉCHARGEMENT SUR :**

[WWW.RG-RACING.COM](http://WWW.RG-RACING.COM)

R&G Racing

Unit 1, Shelley's Lane, East Worldham, Alton, Hampshire, GU34 3AQ

Tel: +44 (0)1420 89007 Fax: +44 (0)1420 87301 [www.rg-racing.com](http://www.rg-racing.com) Email: [info@rg-racing.com](mailto:info@rg-racing.com)



<b><u>OUTILS REQUIS</u></b>	<b><u>VALEURS DE SERRAGE</u></b>
<ul style="list-style-type: none"> <li>CLÉ À CLIQUET + DOUILLE</li> </ul>	M4 BOULON = 8Nm M5 BOULON = 12Nm M6 BOULON = 15Nm M8 BOULON = 20Nm M10 BOULON = 40Nm M12 BOULON = 40Nm

### **LÉGENDE**

<b>ARTICLE NO.</b>	<b>DESCRIPTION</b>	<b>QTÉ</b>
ARTICLE 1	TB0354 – SUPPORT DE PLAQUE	1
ARTICLE 2	M6 RONDELLE	4
ARTICLE 3	LA0002 – FEU DE PLAQUE	1
ARTICLE 4	2.5mm COLLIERS DE SERRAGE (NON INDIQUÉ)	5
ARTICLE 5	666-896-15 – 150mm MANCHON THERMO RÉTRACTABLE (NON INDIQUÉ)	1
ARTICLE 6	REFL3 – RÉFLECTEUR (NON INDIQUÉ)	1

### **SCHÉMA D'ENSEMBLE**

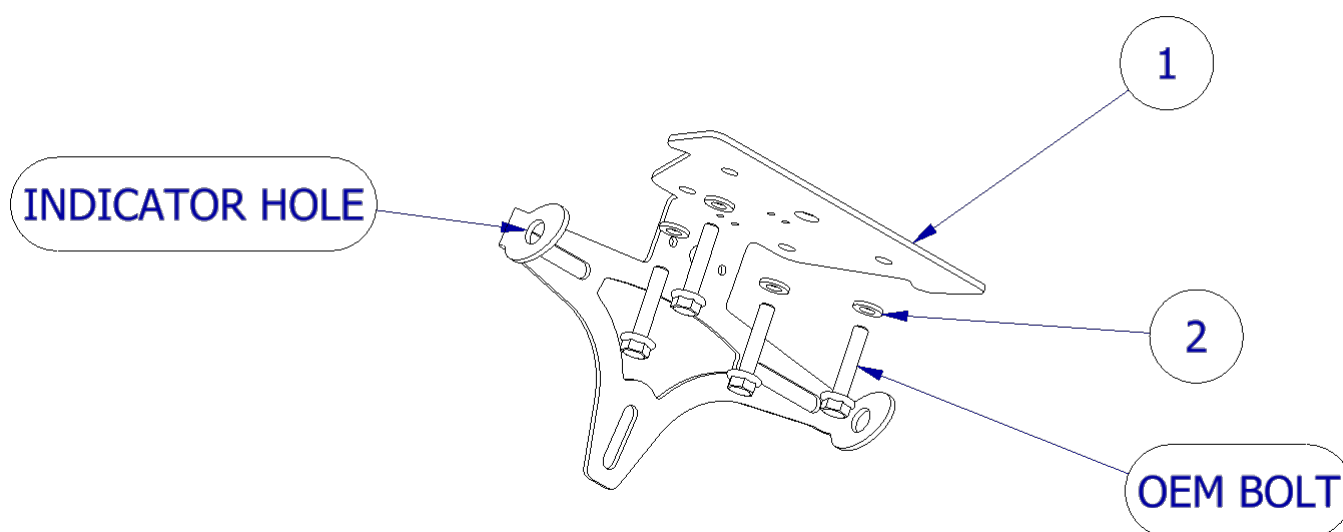

R&G Racing

Unit 1, Shelley's Lane, East Worldham, Alton, Hampshire, GU34 3AQ

Tel: +44 (0)1420 89007 Fax: +44 (0)1420 87301 [www.rg-racing.com](http://www.rg-racing.com) Email: [info@rg-racing.com](mailto:info@rg-racing.com)

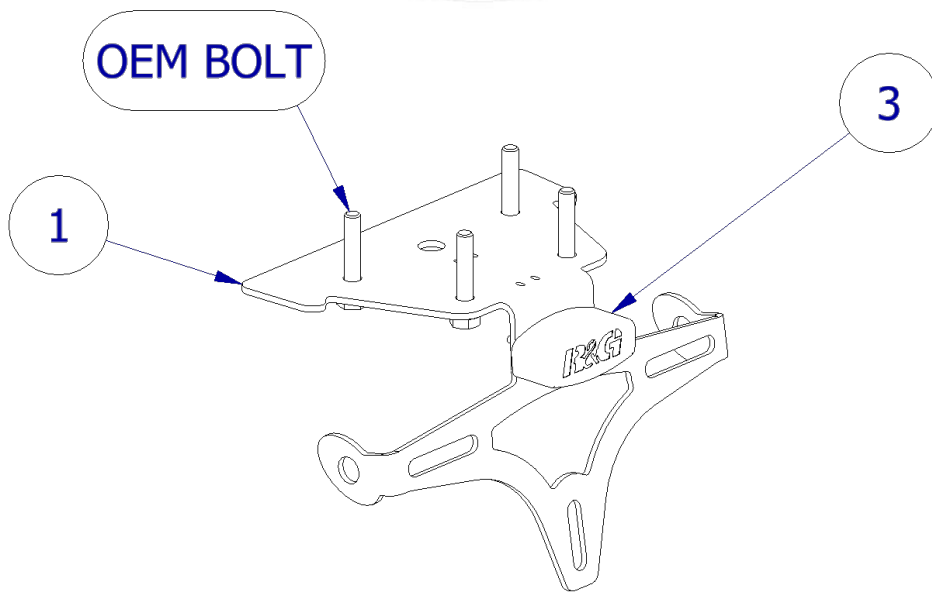

**PHOTOS DE MONTAGE**



**Photo 1**

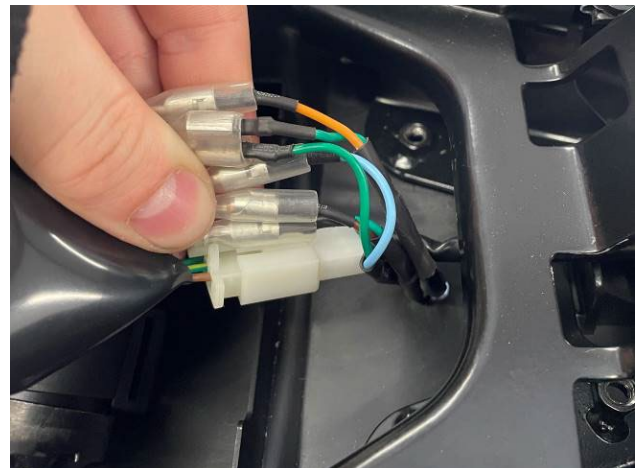

**Photo 2**



**Photo 3**



## **NOTICE DE MONTAGE**

- Commencez par déposer la selle passager à l'aide de la clé.
- Retirez les boulons fixant l'unité de queue d'origine à la moto comme indiqué sur la photo 1.
- Maintenant, avec la queue prête à être soulevée, déconnectez les x6 connecteurs mis en évidence sur la photo 2.
- Conservez les x4 boulons d'origine en toute sécurité de côté, ils seront utilisés pour monter le support de plaque d'immatriculation d'origine sur la moto.
- Enfillez les câbles de clignotant avec le câble LA0002 à travers les trous correspondants dans le support arrière et montez chacun à l'aide des écrous fournis (LA0002) ou d'origine (clignotants).
- Protégez les fils LA0002 en utilisant la gaine thermo rétractable fournie (ARTICLE 5).
- Rangez tous les câbles à l'aide des serre-câbles fournis (ARTICLE 4) et des trous oblongs fournis dans le support de plaque d'immatriculation et faites passer tous les câbles à travers le trou de dégagement central dans le support arrière (comme indiqué sur la photo 3).
- Fixez le support de plaque R&G sur la moto à l'aide des boulons et des rondelles d'origine fournis (ARTICLE 2) comme indiqué sur le SCHÉMA D'ASSEMBLAGE.
- Vérifiez que les clignotants et le feu de plaque d'immatriculation soient correctement câblés et fonctionnent comme il se doit avant de réinstaller le siège.

**IMPORTANT : SI VOUS MONTEZ UNE PLAQUE D'IMMATRICULATION DE GRANDE TAILLE ET LA PLACEZ BIEN EN BAS SUR LE SUPPORT DE PLAQUE D'IMMATRICULATION, IL Y A UN RISQUE QUE LA PLAQUE D'IMMATRICULATION FRAPPE LA ROUE ARRIÈRE SOUS UNE CHARGE LOURDE ET SUR DE GROSSES BOSSES SUR LA ROUTE. IL EST DE VOTRE RESPONSABILITÉ DE VÉRIFIER CETTE POSSIBILITÉ ET DE PRENDRE DES MESURES POUR ÉVITER. NE PAS VÉRIFIER CELA POURRAIT ENTRAÎNER DES BLESSURES GRAVES.**

**Voir plus de produits R&G pour votre moto via ce lien :**

[R&G Racing | Cleaning/Lubrication - Gleam range for All Vehicles \(rg-racing.com\)](http://www.rg-racing.com)

ISSUE 1 – 27/03/2023 - (MH)

### **CONSUMER NOTICE**

The catalogue description and any exhibition of samples are only broad indications of the Products and R&G may make design changes which do not diminish their performance or visual appeal and supplying them in such state shall conform to the order. The Buyer acknowledges no representation or warranty (other than as to title) has been given or will apply to the Products other than those in R&G's order or confirmation and the Buyer confirms it has chosen the Products as being of merchantable quality and suitable for its particular purposes. Where R&G fits the Products or undertakes other services it shall exercise reasonable skill and care and rectify any fault free of charge unless the workmanship has been disturbed. The Buyer is responsible for ensuring that the warranty on the motorcycle is not affected by the fitting of the Products. On return of any defective Products R&G shall at its option either supply a replacement or refund the purchase money but shall not be liable if the Products have been modified or used or maintained otherwise than in accordance with R&G's or manufacturer's instructions and good engineering practice or if the defect arises from accident or neglect. Other than identified above and subject to R&G not limiting its liability for causing death and personal injury, it shall not be liable for indirect or consequential loss and otherwise its liability shall be limited to the amounts paid by the Buyer for the Products or the fitting or service concerned. These terms do not affect the Buyer's statutory rights.

### **R&G RACING RETURNS POLICY (NON-FAULTY GOODS)**

Returns must be pre-authorized (if not pre-authorized the return will be rejected). Goods may only be returned direct to us if they were purchased direct from us (customer must prove if necessary). Otherwise to be returned to original vendor. Goods must be in re-sellable condition, in the opinion of R&G Racing. All returns are subject to a 25% restocking and handling fee (25% of the gross value exc. P&P – at the prevailing price at time of purchase). The customer must pay any and all carriage charges. No returns of discontinued products, unless within 14 days of purchase. This policy does not affect your statutory rights and does not refer to faulty goods.

R&G Racing

Unit 1, Shelley's Lane, East Worldham, Alton, Hampshire, GU34 3AQ

Tel: +44 (0)1420 89007 Fax: +44 (0)1420 87301 [www.rg-racing.com](http://www.rg-racing.com) Email: [info@rg-racing.com](mailto:info@rg-racing.com)





## **MONTAGEANLEITUNG FÜR LP0357 KENNZEICHENHALTER**



**ALLE KIT-TEILE SIND AUF DEN NACHFOLGENDEN SEITEN ABGEBILDET UND GEKENNZEICHNET.**

DIE ABGEBILDETEN TEILE DIENEN LEDIGLICH ZUR ERKLÄRUNG.

ÜBERPRÜFEN SIE ZUERST, DASS ALLE TEILE VORHANDEN SIND.

**LESEN SIE DIE MONTAGEANLEITUNG KOMPLETT DURCH, BEVOR SIE ANFANGEN.**

**WENN SIE BEI DER MONTAGE DIESES PRODUKTES UNSICHER SIND, BITTE EINEN UNSERER HÄNDLER KONTAKTIEREN ODER DAS KIT VON EINEM QUALIFIZIERTEN ZWEIRAD-MECHANIKER MONTIEREN LASSEN.**

DIE VERPACKUNG DER TEILE STELLT NICHT DIE REIHENFOLGE DER MONTAGE DAR.

HINWEIS FÜR KITS MIT PLASTIKUNTERLEGSCHWEIBEN AN DEN SCHRAUBEN –  
DIESE PLASTIK-UNTERLEGSCHWEIBEN WERDEN NICHT FÜR DEN EINBAU BENÖTIGT.

**EINE DIGITALE VERSION DIESER MONTAGEANLEITUNG KANN AUF FOLGENDER SEITE HERUNTERGELADEN WERDEN:**

[WWW.RG-RACING.COM](http://WWW.RG-RACING.COM)

R&G Racing

Unit 1, Shelley's Lane, East Worldham, Alton, Hampshire, GU34 3AQ

Tel: +44 (0)1420 89007 Fax: +44 (0)1420 87301 [www.rg-racing.com](http://www.rg-racing.com) Email: [info@rg-racing.com](mailto:info@rg-racing.com)



<b><u>SIE BENÖTIGEN FOLGENDES WERKZEUG</u></b>	<b><u>ALLGEM. ANZUGSDREHMOMENT</u></b>
<ul style="list-style-type: none"> <li>• STECKSCHLÜSSEL MIT VERLÄNGERUNG</li> </ul>	M4 SCHRAUBE = 8Nm M5 SCHRAUBE = 12Nm M6 SCHRAUBE = 15Nm M8 SCHRAUBE = 20Nm M10 SCHRAUBE = 40Nm M12 SCHRAUBE = 40Nm

### **LIEFERUMFANG**

<b>ARTIKEL NR.</b>	<b>BESCHREIBUNG</b>	<b>MENGE</b>
ARTIKEL 1	TB0354 – KENNZEICHENHALTER	1
ARTIKEL 2	M6 UNTERLEGSSCHEIBE	4
ARTIKEL 3	LA0002 – KENNZEICHENBELEUCHTUNG	1
ARTIKEL 4	2.5mm KABELBINDER (NICHT ABGEBILDET)	5
ARTIKEL 5	666-896-15 – 150mm SCHRUMPFSCHLAUCH (NICHT ABGEBILDET)	1
ARTIKEL 6	REFL3 – RÜCKSTRAHLER (NICHT ABGEBILDET)	1

### **ZUSAMMENBAU - ZEICHNUNG**

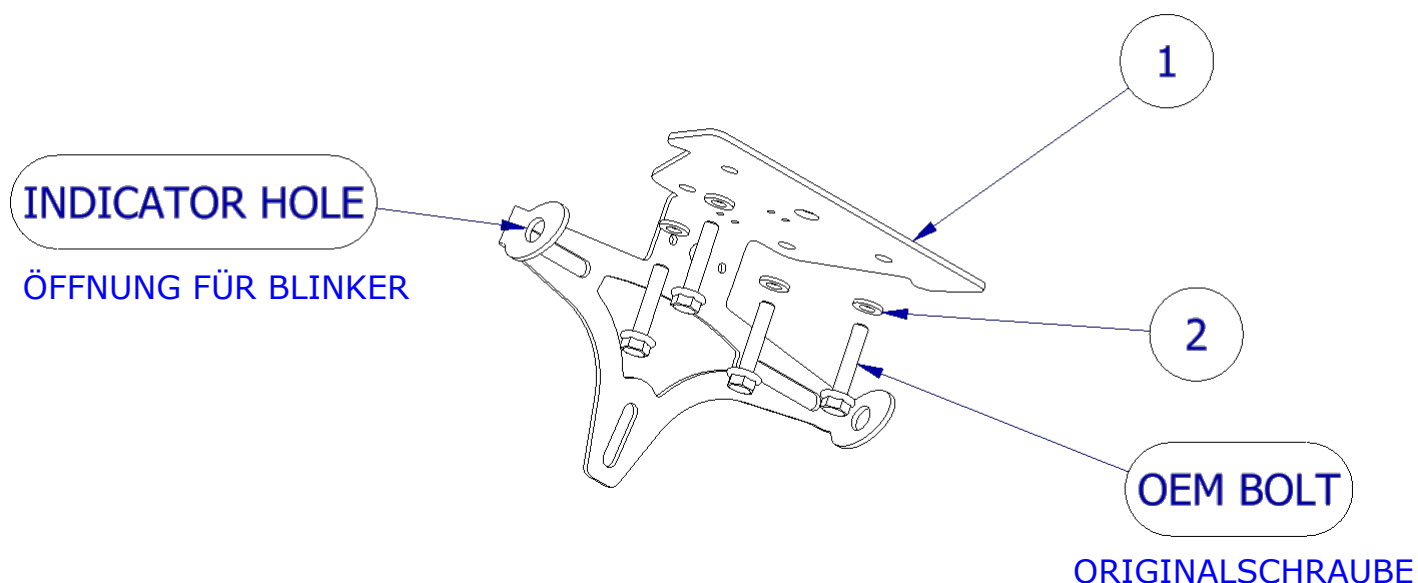

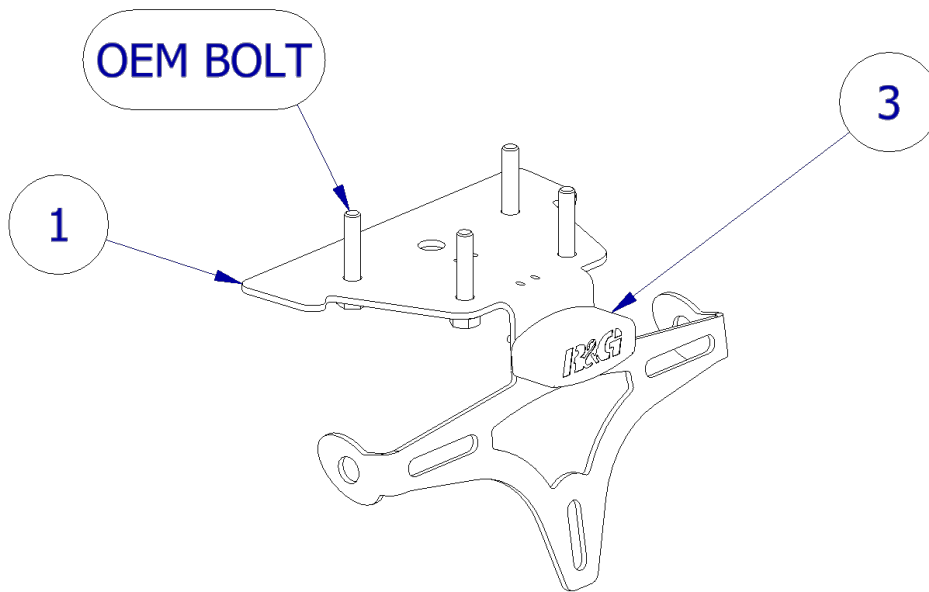

**MONTAGE ABBILDUNGEN**



**Abbildung 1**

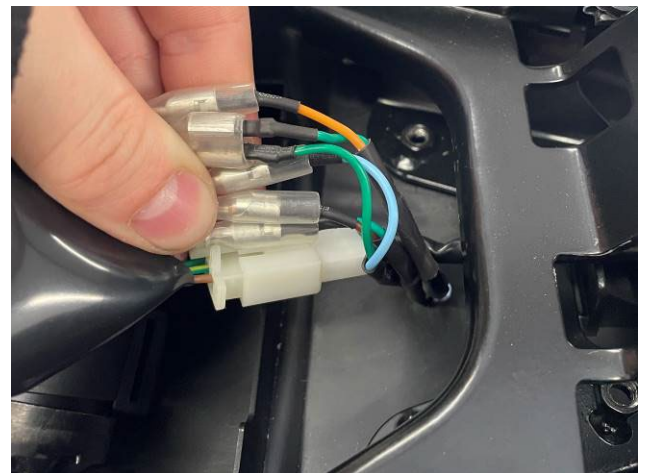

**Abbildung 2**



**Abbildung 3**

**MONTAGEANLEITUNG**

R&G Racing

Unit 1, Shelley's Lane, East Worldham, Alton, Hampshire, GU34 3AQ

Tel: +44 (0)1420 89007 Fax: +44 (0)1420 87301 [www.rg-racing.com](http://www.rg-racing.com) Email: [info@rg-racing.com](mailto:info@rg-racing.com)



- Entfernen Sie den Beifahrersitz (hierfür benötigen Sie den Schlüssel).
- Entfernen Sie die Schrauben, die den original Kennzeichenhalter am Motorrad befestigen wie in **Abbildung 1** abgebildet.
- Nun kann der Kennzeichenhalter entfernt werden – trennen Sie die 6 x Kabelverbindungen, die in **Abbildung 2** gekennzeichnet sind.
- Die 4 x Originalschrauben, die für die Montage des original Kennzeichenhalters benutzt wurden, sicher zur Seite legen.
- Die Kabel für die Blinker zusammen mit dem LA0002 Kabel in die entsprechenden Öffnungen im Kennzeichenhalter einfädeln und jeweils entweder mit den mitgelieferten (LA0002) oder Originalmuttern (Blinker) montieren.
- Die LA0002 Kabel mit dem mitgelieferten Schrumpfschlauch (**ARTIKEL 5**) schützen.
- Die Kabel mittels der mitgelieferten Kabelbinder (**ARTIKEL 4**) und Öffnungen im Kennzeichenhalter ordentlich verstauen und alle Kabel durch die mittlere Öffnung im Kennzeichenhalter fädeln (wie in **Abbildung 3** abgebildet).
- Sichern Sie den R&G Kennzeichenhalter am Motorrad mit den Originalschrauben und mitgelieferten Unterlegscheiben (**ARTIKEL 2**) wie in der **ZEICHNUNG ZUSAMMENBAU** abgebildet.
- Überprüfen Sie, dass die Blinker und die Kennzeichenbeleuchtung korrekt angeschlossen und ordnungsgemäß funktionieren, bevor Sie den Sitz wieder montieren.

**WICHTIG: WENN EIN GROSSES KENNZEICHEN ZU WEIT NACH UNTEN MONTIERT WIRD, BESTEHT BEI SCHWERER LAST ODER DURCH GROSSE BODENWELLEN EIN GERINGES RISIKO, DASS DAS KENNZEICHEN AN DAS HINTERRAD STOSSEN KANN. ES LIEGT IN IHRER VERANTWORTUNG DIES ZU ÜBERPRÜFEN UND, WENN NOTWENDIG, VORBEUGENDE MASSNAHMEN ZU ERGREIFEN. DIE NICHTBEACHTUNG DIESER SICHERHEITSHINWEISES KANN ZU SCHWEREN VERLETZUNGEN FÜHREN.**

**Klicken Sie hier, um weitere R&G Produkte für Ihr Motorrad zu finden:**

[R&G Racing | Cleaning/Lubrication - Gleam range for All Vehicles \(rg-racing.com\)](http://www.rg-racing.com)

AUSGABE 1 – 27/03/2023 - (MH)

#### CONSUMER NOTICE

The catalogue description and any exhibition of samples are only broad indications of the Products and R&G may make design changes which do not diminish their performance or visual appeal and supplying them in such state shall conform to the order. The Buyer acknowledges no representation or warranty (other than as to title) has been given or will apply to the Products other than those in R&G's order or confirmation and the Buyer confirms it has chosen the Products as being of merchantable quality and suitable for its particular purposes. Where R&G fits the Products or undertakes other services it shall exercise reasonable skill and care and rectify any fault free of charge unless the workmanship has been disturbed. The Buyer is responsible for ensuring that the warranty on the motorcycle is not affected by the fitting of the Products. On return of any defective Products R&G shall at its option either supply a replacement or refund the purchase money but shall not be liable if the Products have been modified or used or maintained otherwise than in accordance with R&G's or manufacturer's instructions and good engineering practice or if the defect arises from accident or neglect. Other than identified above and subject to R&G not limiting its liability for causing death and personal injury, it shall not be liable for indirect or consequential loss and otherwise its liability shall be limited to the amounts paid by the Buyer for the Products or the fitting or service concerned. These terms do not affect the Buyer's statutory rights.

#### R&G RACING RETURNS POLICY (NON-FAULTY GOODS)

Returns must be pre-authorized (if not pre-authorized the return will be rejected). Goods may only be returned direct to us if they were purchased direct from us (customer must prove if necessary). Otherwise to be returned to original vendor. Goods must be in re-sellable condition, in the opinion of R&G Racing. All returns are subject to a 25% restocking and handling fee (25% of the gross value exc. P&P – at the prevailing price at time of purchase). The customer must pay any and all carriage charges. No returns of discontinued products, unless within 14 days of purchase. This policy does not affect your statutory rights and does not refer to faulty goods.

R&G Racing

Unit 1, Shelley's Lane, East Worldham, Alton, Hampshire, GU34 3AQ

Tel: +44 (0)1420 89007 Fax: +44 (0)1420 87301 [www.rg-racing.com](http://www.rg-racing.com) Email: [info@rg-racing.com](mailto:info@rg-racing.com)