



FITTING INSTRUCTIONS FOR LP0340 LICENCE PLATE BRACKET



**This kit contains the items pictured and labelled over page.
Some parts may be shown for clarity of instructions only.
Do not proceed until you are sure all parts are present.
Please read all instructions before proceeding.**

**IF IN ANY DOUBT WHEN FITTING OUR PRODUCTS, CONSULT ONE OF OUR DEALERS
OR HAVE FITTED BY A QUALIFIED TECHNICIAN.**

Please note that the way the kit is packed does not necessarily represent the way of mounting to the bike.

In the event of rubber washers being used to hold components onto bolts, these rubber washers can be thrown away.

DIGITAL COPIES OF THESE INSTRUCTIONS ARE AVAILABLE FROM

WWW.RG-RACING.COM

R&G

Unit 1, Shelley's Lane, East Worldham, Alton, Hampshire, GU34 3AQ
Tel: +44 (0)1420 89007 Fax: +44 (0)1420 87301 www.rg-racing.com Email: info@rg-racing.com



<u>TOOLS REQUIRED</u>	<u>GENERAL TORQUE SETTINGS</u>
<ul style="list-style-type: none"> • Set of metric Allen keys. • Set of metric sockets and wrench. <ul style="list-style-type: none"> • 12mm spanner. • Phillips screwdriver. • Cable cutters 	<p>M4 BOLT = 8Nm</p> <p>M5 BOLT = 12Nm</p> <p>M6 BOLT = 15Nm</p> <p>M8 BOLT = 20Nm</p> <p>M10 BOLT = 40Nm</p> <p>M12 BOLT = 40Nm</p>

LEGEND

ITEM No.	DESCRIPTION	QTY
ITEM 1	LICENCE PLATE BRACKET	1
ITEM 2	MAIN SUPPORT BRACKET	1
ITEM 3	COVER PLATE	1
ITEM 4	M5 COUNTERSUNK BOLT	7
ITEM 5	M5 WASHERS	7
ITEM 6	LA0002 NUMBER PLATE LIGHT & SHROUD	1
ITEM 7	M5 NYLOC NUTS	7
ITEM 8	M6 BUTTON HEAD BOLT	4
ITEM 9	M6 WASHERS	4
ITEM 10	2.5MM CABLE TIES	4
ITEM 11	SELF ADHESIVE CABLE CLIP	2
ITEM 12	REFLECTOR	1
ITEM 13	150mm LENGTH OF HEAT SHRINK	1
ITEM 14	CON0014 WIRING ADAPTOR (SEE PICTURE 14 FOR ILLUSTRATION)	1

R&G

Unit 1, Shelley's Lane, East Worldham, Alton, Hampshire, GU34 3AQ

Tel: +44 (0)1420 89007 Fax: +44 (0)1420 87301 www.rg-racing.com Email: info@rg-racing.com



ASSEMBLY DIAGRAMS

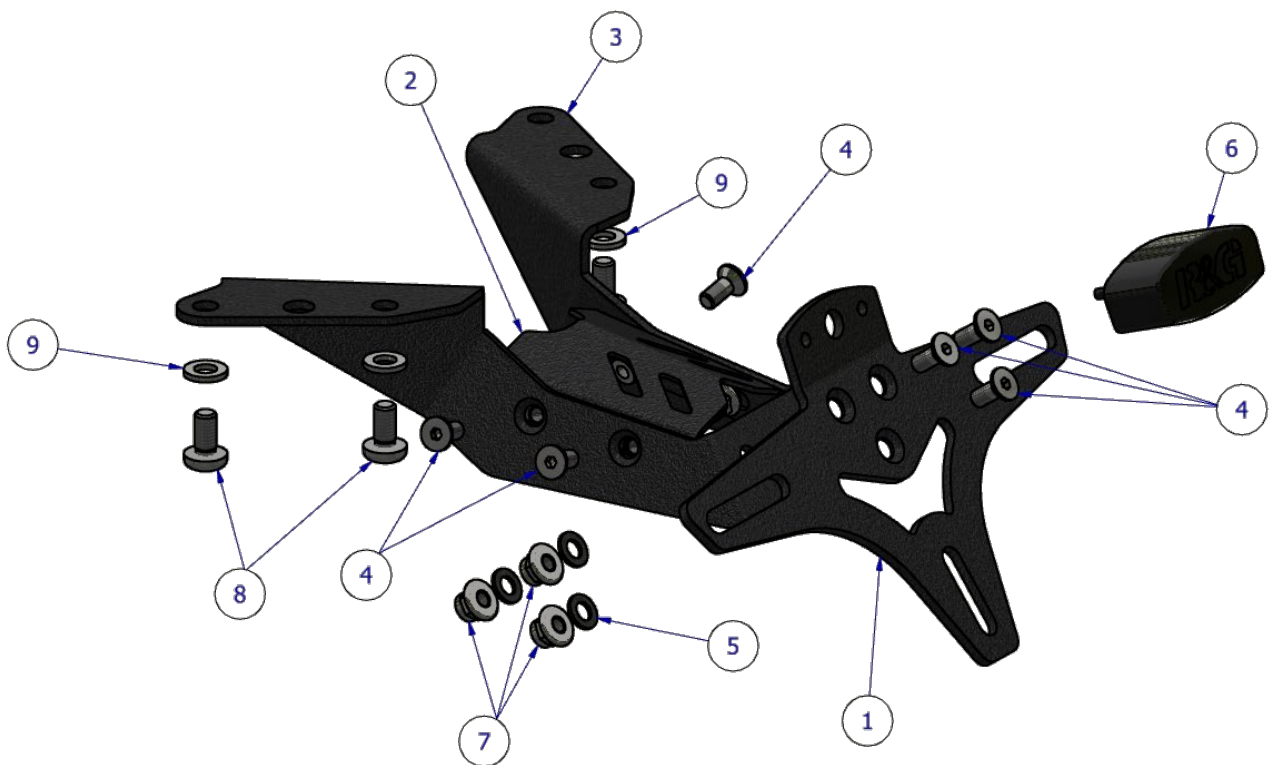
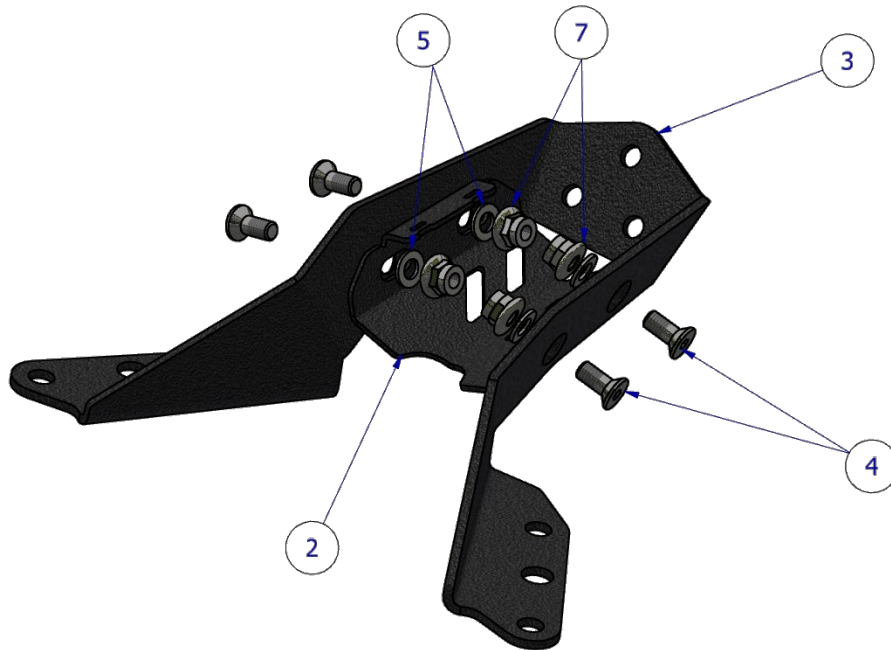

R&G

Unit 1, Shelley's Lane, East Worldham, Alton, Hampshire, GU34 3AQ

Tel: +44 (0)1420 89007 Fax: +44 (0)1420 87301 www.rg-racing.com Email: info@rg-racing.com

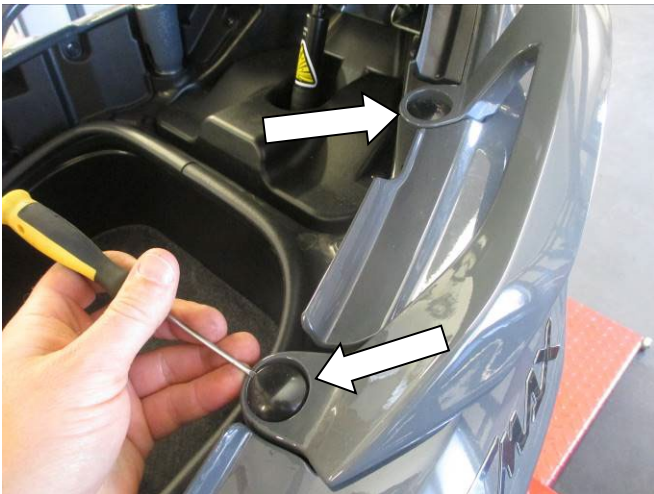
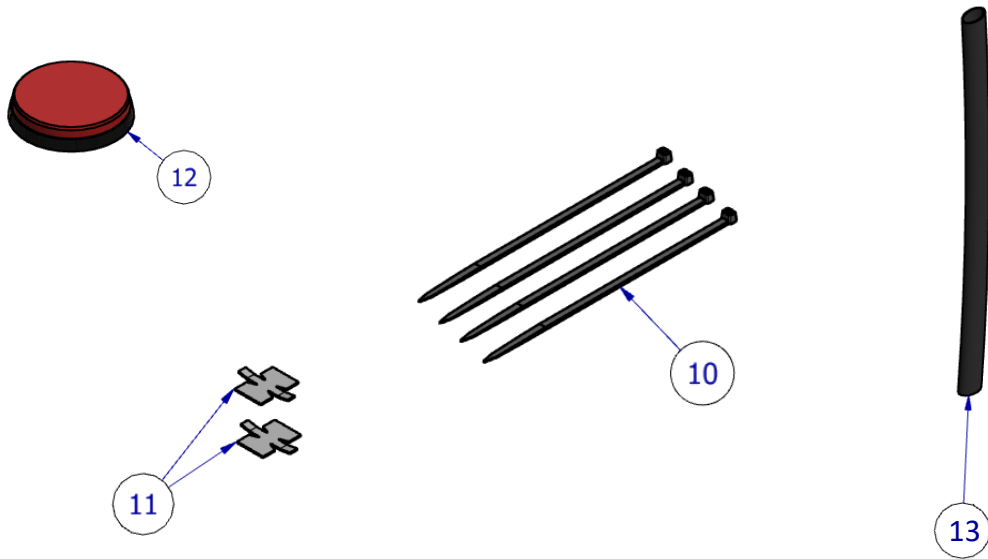

Picture 1



Picture 2



Picture 3



Picture 4



Picture 5



Picture 6



Picture 7



Picture 8

R&G

Unit 1, Shelley's Lane, East Worldham, Alton, Hampshire, GU34 3AQ

Tel: +44 (0)1420 89007 Fax: +44 (0)1420 87301 www.rg-racing.com Email: info@rg-racing.com



Picture 9



Picture 10

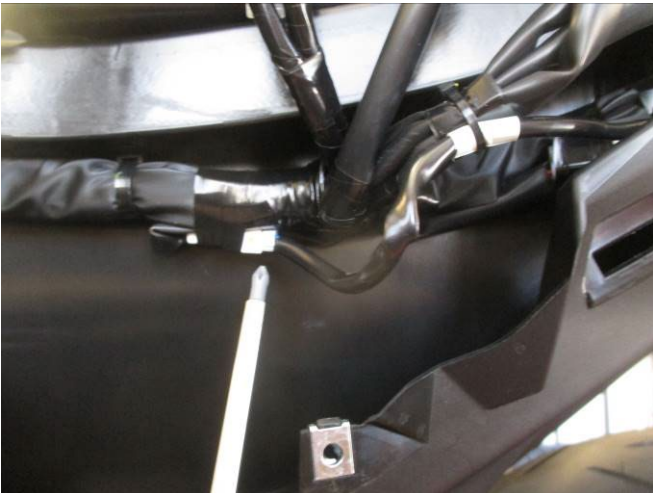

Picture 11

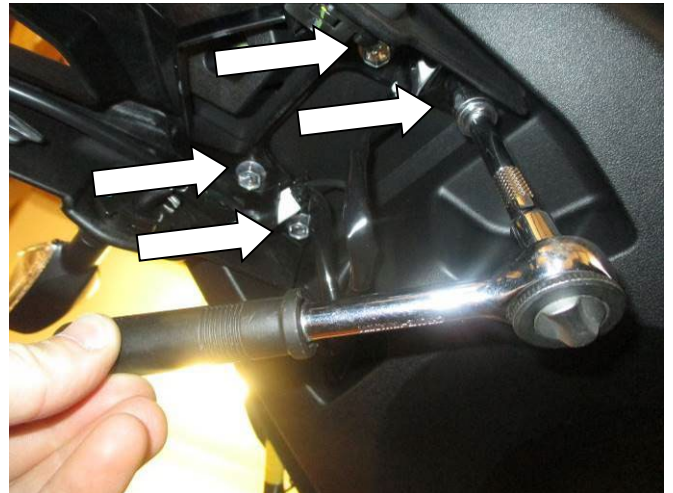

Picture 12



Picture 13

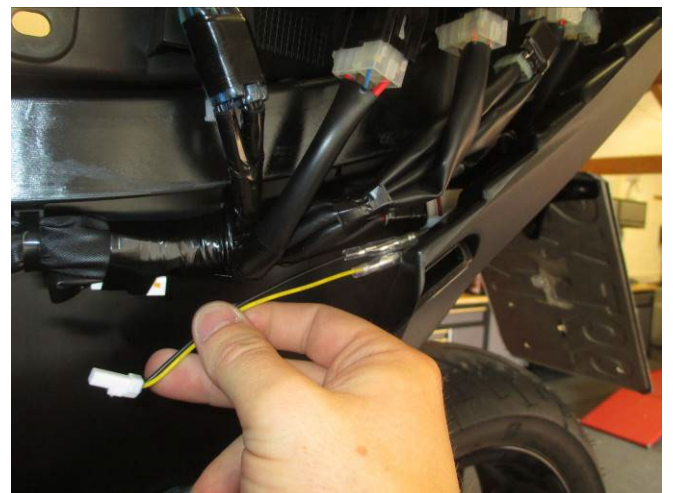

Picture 14



Picture 15

FITTING INSTRUCTIONS

- To fit the R&G tail tidy, lift the seat using the key and release button.
- Remove the two plastic covers on the handrail on the left side of the bike, as arrowed in picture 1, and remove the two bolts underneath. Remove the handrail from the bike.
- Remove the rubber panel adjoining the rear panels to gain access to the bolts underneath, as shown in picture 2.
- Unclip and remove the rubber cover shown in picture 3 and remove the bolt shown in picture 4.
- Remove the bolts shown in pictures 5-10. This will allow you to remove the side panel shown in picture 5, and allow access to the final bolt to remove in order to remove the larger side panel which will reveal the wiring for the OEM tail unit.
- Disconnect the connector shown in picture 11 and cut any cable ties securing the tail unit wiring to the bike.
- While supporting the tail unit Remove the 4 x hex bolts in the underside of the OEM tail unit as shown in picture 12.
- Remove the OEM tail unit from the bike ensuring to pass the wiring through the opening in the LHS of the bike and remove completely.
- Offer the cover plate (**Item 3**) up to the main bracket (**Item 2**) and secure in place using 4 of the M5 countersunk bolts (**Item 4**), M5 washers (**Item 5**) and M5 nyloc nuts (**Item 7**).
- Feed the wire of the new R&G licence plate illuminator (**Item 6**) through the upper central hole in the new licence plate bracket (**Item 1**) and underneath the cover plate (**Item 3**).
- Secure the illuminator using the M3 washers and nuts supplied as shown in picture 13.
- Fit one length of heat-shrink (**Item 13**) to the wires and heat gently to shrink to fit.
- Fit the light shroud and use a small amount of adhesive to hold it in position; this will help direct the light correctly.
- Neatly route the wiring with the licence plate illuminator wiring using the cable ties and cable clips supplied.
- Take the tail tidy assembly and offer it up underneath the tail whilst feeding the wire up through the small hole where the OEM wiring exited from, attach the CON0014 adaptor (**Item 14**) as shown in picture 14 and plug the CON0014 into the OEM harness.

R&G

Unit 1, Shelley's Lane, East Worldham, Alton, Hampshire, GU34 3AQ

Tel: +44 (0)1420 89007 Fax: +44 (0)1420 87301 www.rg-racing.com Email: info@rg-racing.com



- Take the four M6 x 16mm long button head bolts (**Item 8**) and four M6 washers (**Item 9**) and fit through the four mounting holes of the tail tidy before tightening into the threaded bosses on the subframe, as shown in picture 15.
- Check for the correct operation of all lights, if illumination fails on any light, re-connect the bullet connectors the other way around.
- Ensure the wiring is all neatly routed behind the panel using the cable ties (**Item 10**) and self-adhesive cable clips (**Item 11**).
- Re-fit the bodywork and the hand-rails in a reverse procedure of how they were removed.
- Re-fit the licence plate (it may require drilling).
- Depending on local laws, attach enclosed reflector (**Item 12**) in an appropriate location.
- Test the licence plate illuminator and all lights before riding.
- **IMPORTANT: IF FITTING A FULL-SIZE LICENCE PLATE AND PLACING IT FAR DOWN ON THE LICENCE PLATE HANGER, THERE IS A SMALL CHANCE OF THE LICENCE PLATE HITTING THE BACK WHEEL UNDER HEAVY LOAD AND OVER LARGE BUMPS IN THE ROAD. IT IS YOUR RESPONSIBILITY TO CHECK FOR THIS POSSIBILITY AND TAKE AVOIDING ACTION. FAILURE TO CHECK THIS COULD RESULT IN SERIOUS INJURY.**

ISSUE 1 26/10/2022 (MH)

CONSUMER NOTICE

The catalogue description and any exhibition of samples are only broad indications of the Products and R&G may make design changes which do not diminish their performance or visual appeal and supplying them in such state shall conform to the order. The Buyer acknowledges no representation or warranty (other than as to title) has been given or will apply to the Products other than those in R&G's order or confirmation and the Buyer confirms it has chosen the Products as being of merchantable quality and suitable for its particular purposes. Where R&G fits the Products or undertakes other services it shall exercise reasonable skill and care and rectify any fault free of charge unless the workmanship has been disturbed. The Buyer is responsible for ensuring that the warranty on the motorcycle is not affected by the fitting of the Products. On return of any defective Products R&G shall at its option either supply a replacement or refund the purchase money but shall not be liable if the Products have been modified or used or maintained otherwise than in accordance with R&G's or manufacturer's instructions and good engineering practice or if the defect arises from accident or neglect. Other than identified above and subject to R&G not limiting its liability for causing death and personal injury, it shall not be liable for indirect or consequential loss and otherwise its liability shall be limited to the amounts paid by the Buyer for the Products or the fitting or service concerned. These terms do not affect the Buyer's statutory rights.

R&G RACING RETURNS POLICY (NON-FAULTY GOODS)

Returns must be pre-authorized (if not pre-authorized the return will be rejected). Goods may only be returned direct to us if they were purchased direct from us (customer must prove if necessary). Otherwise to be returned to original vendor. Goods must be in re-sellable condition, in the opinion of R&G Racing. All returns are subject to a 25% restocking and handling fee (25% of the gross value exc. P&P – at the prevailing price at time of purchase). The customer must pay any and all carriage charges. No returns of discontinued products, unless within 14 days of purchase. This policy does not affect your statutory rights and does not refer to faulty goods.

R&G

Unit 1, Shelley's Lane, East Worldham, Alton, Hampshire, GU34 3AQ

Tel: +44 (0)1420 89007 Fax: +44 (0)1420 87301 www.rg-racing.com Email: info@rg-racing.com



NOTICE DE MONTAGE POUR LP0340 SUPPORT DE PLAQUE



CE KIT CONTIENT LES ARTICLES ILLUSTRÉS ET ÉTIQUETES SUR LA PAGE.

CERTAINES PARTIES PEUVENT ÊTRE PRÉSENTES UNIQUEMENT POUR LA CLARTÉ DES INSTRUCTIONS.

NE PAS PROCÉDER AU MONTAGE TANT QUE VOUS N'ÊTES PAS SÛR QUE TOUTES LES PIÈCES SOIENT PRÉSENTES.

VEUILLEZ LIRE TOUTES LES INSTRUCTIONS AVANT DE CONTINUER.

EN CAS DE DOUTE LORS DU MONTAGE DE NOS PRODUITS, CONSULTEZ UN DE NOS REVENDEURS OU FAITES APPEL À UN TECHNICIEN QUALIFIÉ.

VEUILLEZ NOTER QUE LA FAÇON DONT LE KIT EST EMBALLÉ NE REPRÉSENTE PAS NECESSAIREMENT LA MANIÈRE DE LE MONTER SUR LA MOTO.

SI DES RONDELLES EN CAOUTCHOUC SONT UTILISÉES POUR MAINTENIR LES COMPOSANTS SUR LES BOULONS, ELLES PEUVENT ÊTRE JETÉES.

NOTICE DISPONIBLE AU TÉLÉCHARGEMENT SUR :
WWW.RG-RACING.COM

R&G

Unit 1, Shelley's Lane, East Worldham, Alton, Hampshire, GU34 3AQ
Tel: +44 (0)1420 89007 Fax: +44 (0)1420 87301 www.rg-racing.com Email: info@rg-racing.com



<u>OUTILS REQUIS</u>	<u>VALEURS DE SERRAGE</u>
<ul style="list-style-type: none"> • Clés Allen • Clé à cliquet + douilles. • Clé à molette 12mm • Tournevis cruciforme • Pince coupante 	M4 BOULON = 8Nm M5 BOULON = 12Nm M6 BOULON = 15Nm M8 BOULON = 20Nm M10 BOULON = 40Nm M12 BOULON = 40Nm

LÉGENDE

ARTICLE No.	DESCRIPTION	QTÉ
ARTICLE 1	SUPPORT DE PLAQUE	1
ARTICLE 2	SUPPORT PRINCIPAL	1
ARTICLE 3	PROTECTION	1
ARTICLE 4	M5 BOULON	7
ARTICLE 5	M5 RONDELLES	7
ARTICLE 6	LA0002 FEU DE PLAQUE ET PROTECTION	1
ARTICLE 7	M5 ÉCROUS	7
ARTICLE 8	M6 BOULON	4
ARTICLE 9	M6 RONDELLES	4
ARTICLE 10	2.5MM COLLIERS DE SERRAGE	4
ARTICLE 11	CLIP CÂBLE AUTOCOLLANT	2
ARTICLE 12	RÉFLECTEUR	1
ARTICLE 13	150mm LONGUEUR DE MANCHON THERMO RÉTRACTABLE	1
ARTICLE 14	CON0014 ADAPTATEUR DE CÂBLAGE (VOIR PHOTO 14 POUR ILLUSTRATION)	1

R&G

Unit 1, Shelley's Lane, East Worldham, Alton, Hampshire, GU34 3AQ

Tel: +44 (0)1420 89007 Fax: +44 (0)1420 87301 www.rg-racing.com Email: info@rg-racing.com



SCHÉMAS D'ASSEMBLAGE

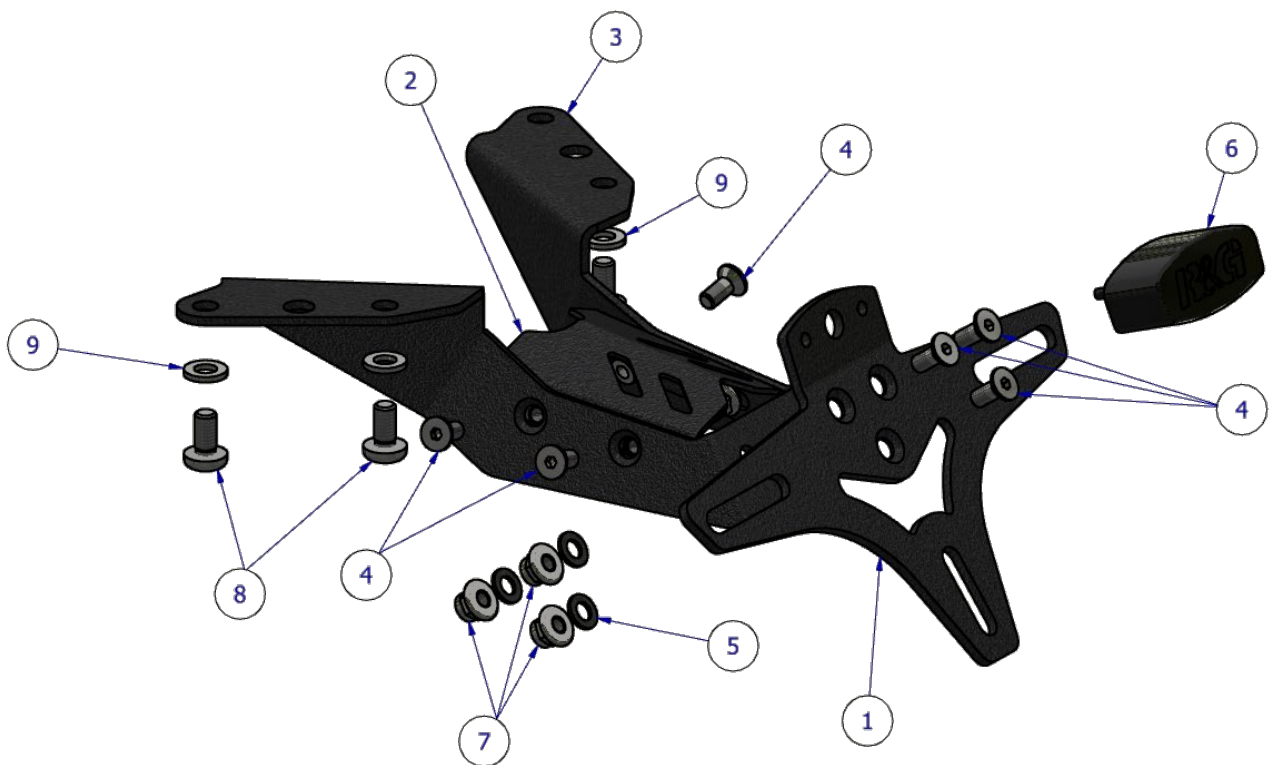
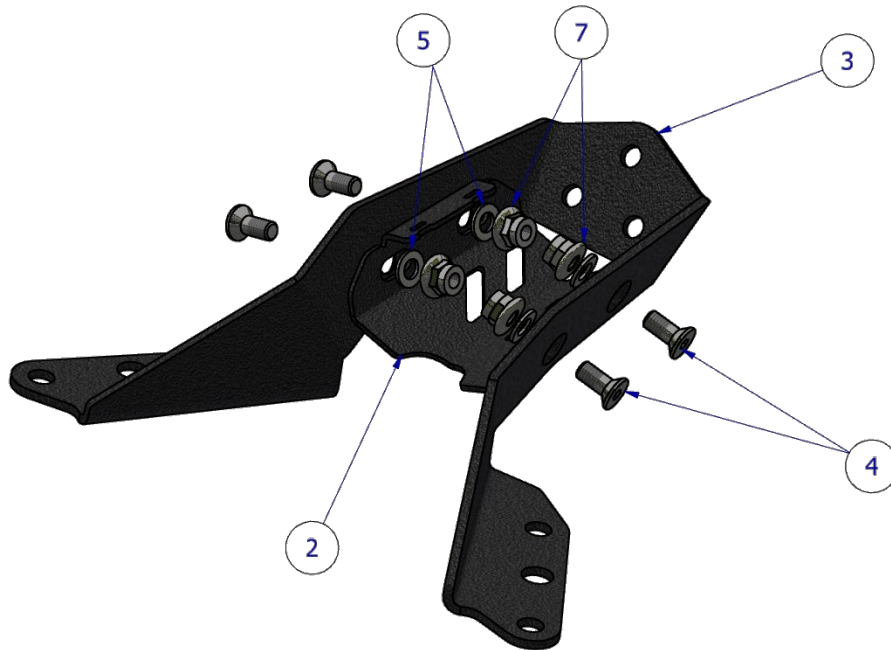

R&G

Unit 1, Shelley's Lane, East Worldham, Alton, Hampshire, GU34 3AQ

Tel: +44 (0)1420 89007 Fax: +44 (0)1420 87301 www.rg-racing.com Email: info@rg-racing.com

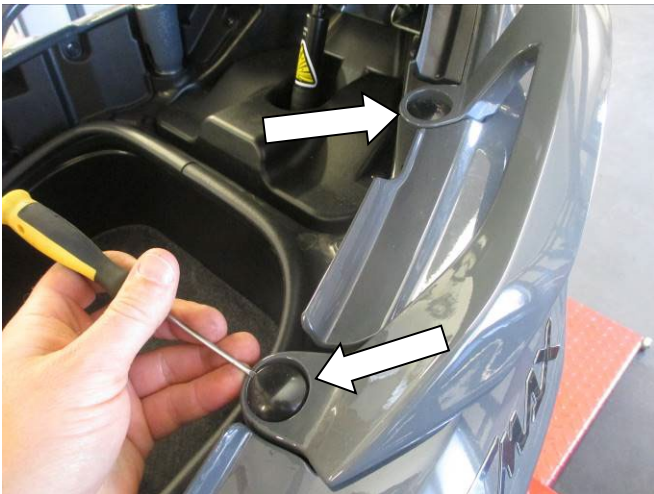
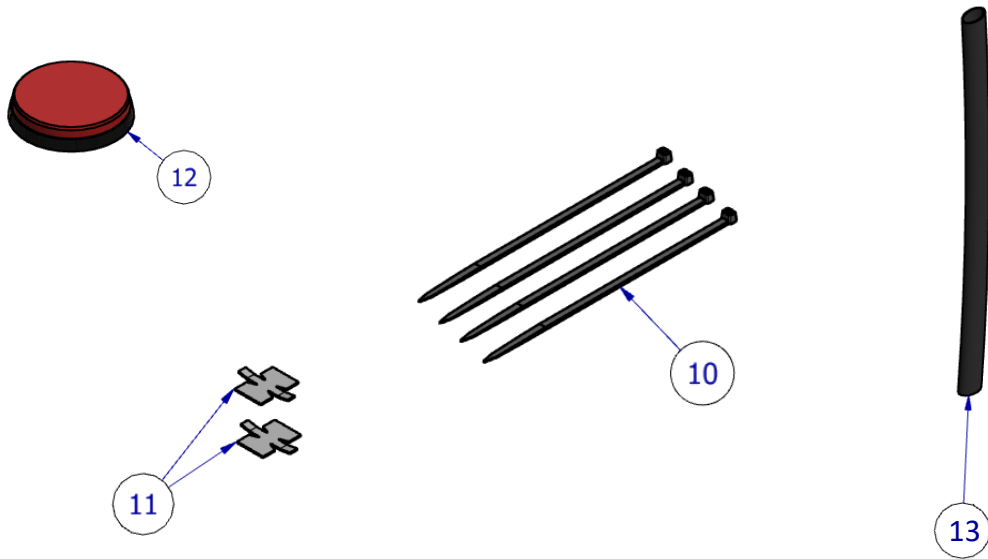

Photo 1



Photo 2



Photo 3



Photo 4



Photo 5



Photo 6



Photo 7



Photo 8

R&G



Photo 9



Photo 10

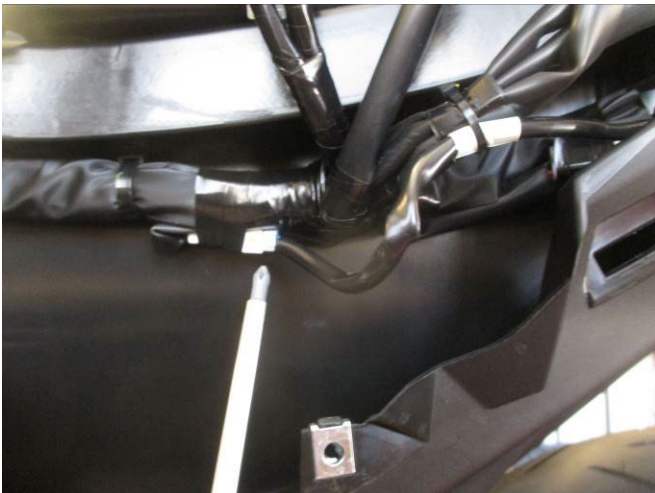

Photo 11

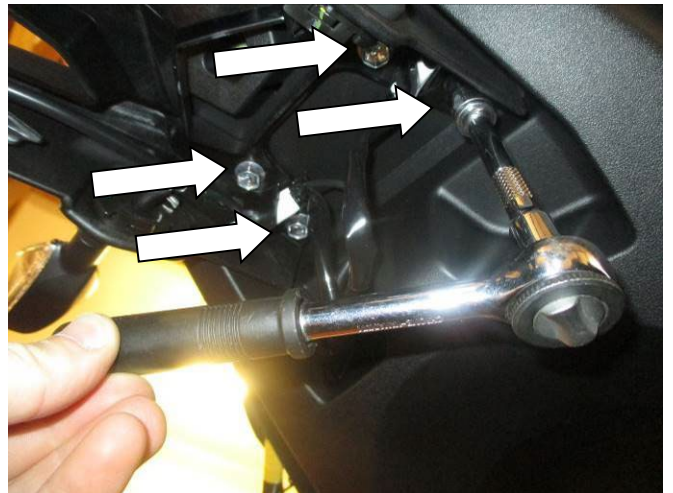

Photo 12

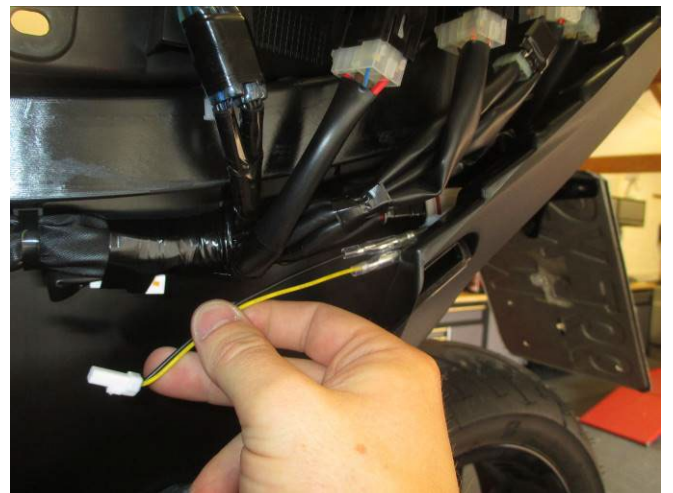



Photo 13

Photo 14



Photo 15

NOTICE DE MONTAGE

- Pour installer le support arrière R&G, soulevez le siège à l'aide de la clé et du bouton de déverrouillage.
- Retirez les deux couvercles en plastique sur la main courante du côté gauche de la moto, comme indiqué sur la photo 1, et retirez les deux boulons en dessous. Retirez la main courante de la moto.
- Retirez le panneau en caoutchouc attaché aux panneaux arrière pour accéder aux boulons situés en dessous, comme indiqué sur la photo 2.
- Déclipsez et retirez le cache en caoutchouc indiqué sur la photo 3 et retirez le boulon indiqué sur la photo 4.
- Retirez les boulons indiqués sur les photos 5-10. Cela vous permettra de retirer le panneau latéral illustré sur la photo 5 et d'accéder au dernier boulon à retirer afin de retirer le plus grand panneau latéral qui révélera le câblage de l'unité d'origine.
- Débranchez le connecteur illustré sur la photo 11 et coupez les éventuels colliers de serrage fixant le câblage de l'empennage de la moto.
- Tout en soutenant l'unité, retirez les 4 boulons hexagonaux sous l'unité d'origine comme indiqué sur la photo 12.
- Retirez l'unité d'origine de la moto en veillant à faire passer le câblage à travers l'ouverture dans la partie gauche de la moto et retirez-le complètement.
- Présentez la plaque de couverture (article 3) sur le support principal (article 2) et fixez-la à l'aide de 4 des boulons à tête fraisée M5 (article 4), des rondelles M5 (article 5) et des écrous nyloc M5 (article 7).
- Faites passer le fil du nouveau feu de plaque d'immatriculation R&G (article 6) à travers le trou central supérieur du nouveau support de plaque d'immatriculation (article 1) et sous la plaque de recouvrement (article 3).
- Fixez le feu à l'aide des rondelles et des écrous M3 fournis comme indiqué sur la photo 13.
- Installez une longueur de gaine thermo rétractable (article 13) sur les fils et chauffez doucement pour rétrécir à l'ajustement.

R&G

Unit 1, Shelley's Lane, East Worldham, Alton, Hampshire, GU34 3AQ

Tel: +44 (0)1420 89007 Fax: +44 (0)1420 87301 www.rg-racing.com Email: info@rg-racing.com



- Montez le cache-feu et utilisez une petite quantité d'adhésif pour le maintenir en position ; cela aidera à diriger l'éclairage correctement.
- Acheminez soigneusement le câblage avec le câblage de l'éclairage de la plaque d'immatriculation à l'aide des serre-câbles et des serre-câbles fournis.
- Prenez l'ensemble du support et placez-le sous la queue tout en faisant passer le fil à travers le petit trou d'où sort le câblage d'origine, fixez l'adaptateur CON0014 (article 14) comme indiqué sur la photo 14 et branchez le CON0014 dans le faisceau d'origine.
- Prenez les quatre boulons à tête ronde M6 x 16 mm de long (article 8) et les quatre rondelles M6 (article 9) et insérez-les dans les quatre trous de montage du cache arrière avant de les serrer dans les bossages filetés du faux-châssis, comme indiqué sur la photo 15.
- Vérifiez le bon fonctionnement de tous les feux, si l'éclairage échoue sur n'importe quel feu, rebranchez les connecteurs dans l'autre sens.
- Assurez-vous que le câblage soit bien acheminé derrière le panneau à l'aide des serre-câbles (article 10) et des serre-câbles autocollants (article 11).
- Remonter le carénage et les mains courantes en procédant dans l'ordre inverse de la dépose.
- Remontez la plaque d'immatriculation (cela peut nécessiter un perçage).
- En fonction des lois locales, fixez le réflecteur fourni (article 12) à un endroit approprié.
- **Testez le fonctionnement de tous les feux avant de rouler.**
- **IMPORTANT : SI VOUS MONTEZ UNE PLAQUE D'IMMATRICULATION DE GRANDE TAILLE ET LA PLACEZ BIEN EN BAS SUR LE SUPPORT DE PLAQUE D'IMMATRICULATION, IL Y A UN RISQUE QUE LA PLAQUE D'IMMATRICULATION FRAPPE LA ROUE ARRIÈRE SOUS UNE CHARGE LOURDE ET SUR DE GROSSES BOSSES SUR LA ROUTE. IL EST DE VOTRE RESPONSABILITÉ DE VÉRIFIER CETTE POSSIBILITÉ ET DE PRENDRE DES MESURES POUR ÉVITER. NE PAS VÉRIFIER CELA POURRAIT ENTRAÎNER DES BLESSURES GRAVES.**

ISSUE 1 26/10/2022 (MH)

CONSUMER NOTICE

The catalogue description and any exhibition of samples are only broad indications of the Products and R&G may make design changes which do not diminish their performance or visual appeal and supplying them in such state shall conform to the order. The Buyer acknowledges no representation or warranty (other than as to title) has been given or will apply to the Products other than those in R&G's order or confirmation and the Buyer confirms it has chosen the Products as being of merchantable quality and suitable for its particular purposes. Where R&G fits the Products or undertakes other services it shall exercise reasonable skill and care and rectify any fault free of charge unless the workmanship has been disturbed. The Buyer is responsible for ensuring that the warranty on the motorcycle is not affected by the fitting of the Products. On return of any defective Products R&G shall at its option either supply a replacement or refund the purchase money but shall not be liable if the Products have been modified or used or maintained otherwise than in accordance with R&G's or manufacturer's instructions and good engineering practice or if the defect arises from accident or neglect. Other than identified above and subject to R&G not limiting its liability for causing death and personal injury, it shall not be liable for indirect or consequential loss and otherwise its liability shall be limited to the amounts paid by the Buyer for the Products or the fitting or service concerned. These terms do not affect the Buyer's statutory rights.

R&G RACING RETURNS POLICY (NON-FAULTY GOODS)

Returns must be pre-authorized (if not pre-authorized the return will be rejected). Goods may only be returned direct to us if they were purchased direct from us (customer must prove if necessary). Otherwise to be returned to original vendor. Goods must be in re-sellable condition, in the opinion of R&G Racing. All returns are subject to a 25% restocking and handling fee (25% of the gross value exc. P&P – at the prevailing price at time of purchase). The customer must pay any and all carriage charges. No returns of discontinued products, unless within 14 days of purchase. This policy does not affect your statutory rights and does not refer to faulty goods.

R&G

Unit 1, Shelley's Lane, East Worldham, Alton, Hampshire, GU34 3AQ

Tel: +44 (0)1420 89007 Fax: +44 (0)1420 87301 www.rg-racing.com Email: info@rg-racing.com



MONTAGEANLEITUNG FÜR LP0340 KENNZEICHENHALTER



Alle Kit-Teile sind auf den folgenden Seiten abgebildet und gekennzeichnet

Die abgebildeten Teile dienen lediglich zur Erklärung.

Überprüfen Sie zuerst, dass alle Teile vorhanden sind.

Lesen Sie die Montageanleitung komplett durch, bevor Sie anfangen

**WENN SIE BEI DER MONTAGE DIESES PRODUKTES UNSICHER SIND, BITTE EINEN
UNSERER HÄNDLER KONTAKTIEREN ODER DAS KIT VON EINEM QUALIFIZIERTEN
ZWEIRAD-MECHANIKER MONTIEREN LASSEN.**

Die Verpackung der Teile stellt nicht die Reihenfolge der Montage dar.

Hinweis für Kits mit Plastikunterlegscheiben an den Schrauben – Diese Plastik-
Unterlegscheiben werden nicht für den Einbau benötigt!

**EINE DIGITALE VERSION DIESER MONTAGEANLEITUNG KANN AUF FOLGENDER
SEITE HERUNTERGELADEN WERDEN:**

WWW.RG-RACING.COM

R&G

Unit 1, Shelley's Lane, East Worldham, Alton, Hampshire, GU34 3AQ

Tel: +44 (0)1420 89007 Fax: +44 (0)1420 87301 www.rg-racing.com Email: info@rg-racing.com



<u>SIE BENÖTIGEN FOLGENDES:</u>	<u>ALLGEM. ANZUGSDREHMOMENT:</u>
<ul style="list-style-type: none"> • Satz Inbusschlüssel • Satz Steckschlüssel • 12mm Schraubenschlüssel • Kreuzschlitz-Schraubenzieher <ul style="list-style-type: none"> • Seitenschneider 	<p>M4 SCHRAUBE = 8Nm</p> <p>M5 SCHRAUBE = 12Nm</p> <p>M6 SCHRAUBE = 15Nm</p> <p>M8 SCHRAUBE = 20Nm</p> <p>M10 SCHRAUBE = 40Nm</p> <p>M12 SCHRAUBE = 40Nm</p>

LIEFERUMFANG

ARTIKEL NR.	BESCHREIBUNG	MENGE
ARTIKEL 1	KENNZEICHENHALTER	1
ARTIKEL 2	HAUPT-HALTERUNG	1
ARTIKEL 3	ABDECKPLATTE	1
ARTIKEL 4	M5 SENKSCHRAUBE	7
ARTIKEL 5	M5 UNTERLEGSCHIEBE	7
ARTIKEL 6	LA0002 KENNZEICHENBELEUCHTUNG & ABDECKUNG	1
ARTIKEL 7	M5 SELBSTSICHERNDE MUTTER	7
ARTIKEL 8	M6 INBUSSCHRAUBE	4
ARTIKEL 9	M6 UNTERLEGSCHIEBE	4
ARTIKEL 10	2.5MM KABELBINDER	4
ARTIKEL 11	SELBSTSICHERNDE KABELCLIP	2
ARTIKEL 12	RÜCKSTRAHLER	1
ARTIKEL 13	150mm SCHRUMPFSCHLAUCH	1
ARTIKEL 14	CON0014 ADAPTER FÜR KABEL (SIEHE ABBILDUNG 14 FOR ILLUSTRATION)	1

R&G

Unit 1, Shelley's Lane, East Worldham, Alton, Hampshire, GU34 3AQ

Tel: +44 (0)1420 89007 Fax: +44 (0)1420 87301 www.rg-racing.com Email: info@rg-racing.com



ZUSAMMENBAU - ZEICHNUNGEN

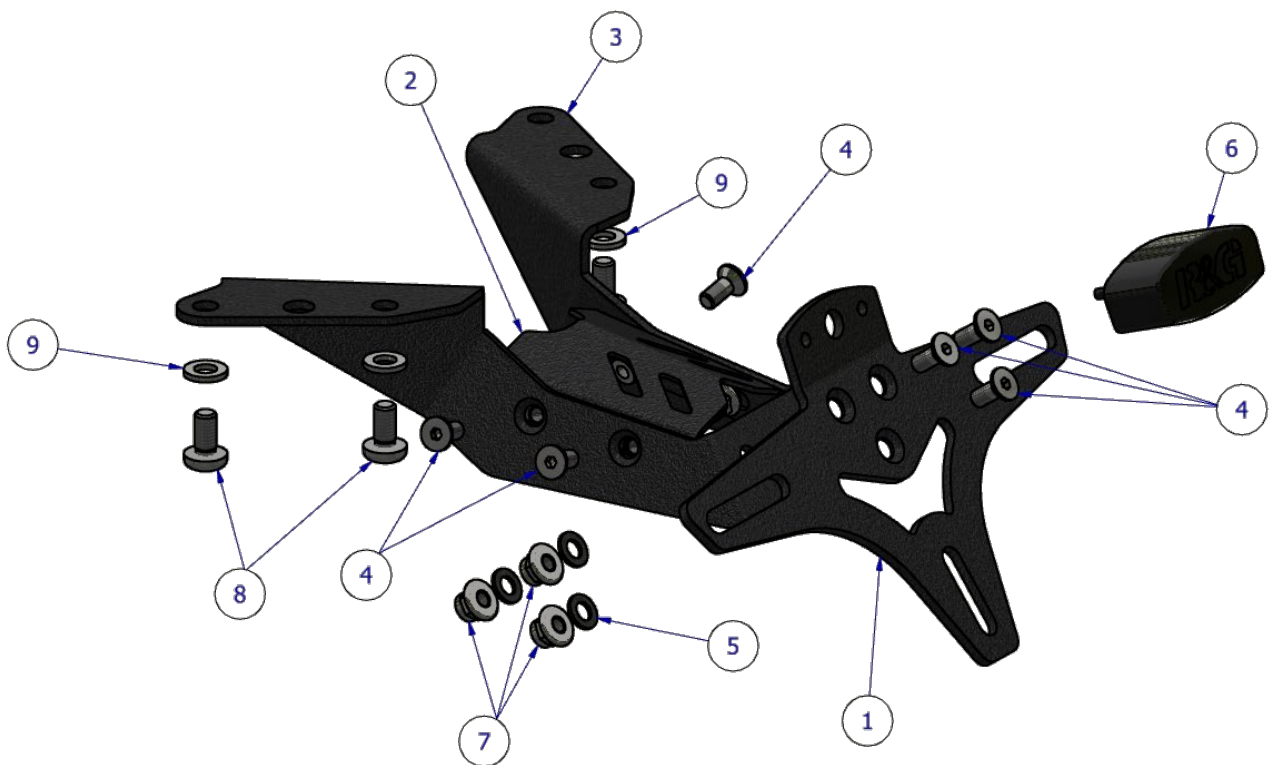
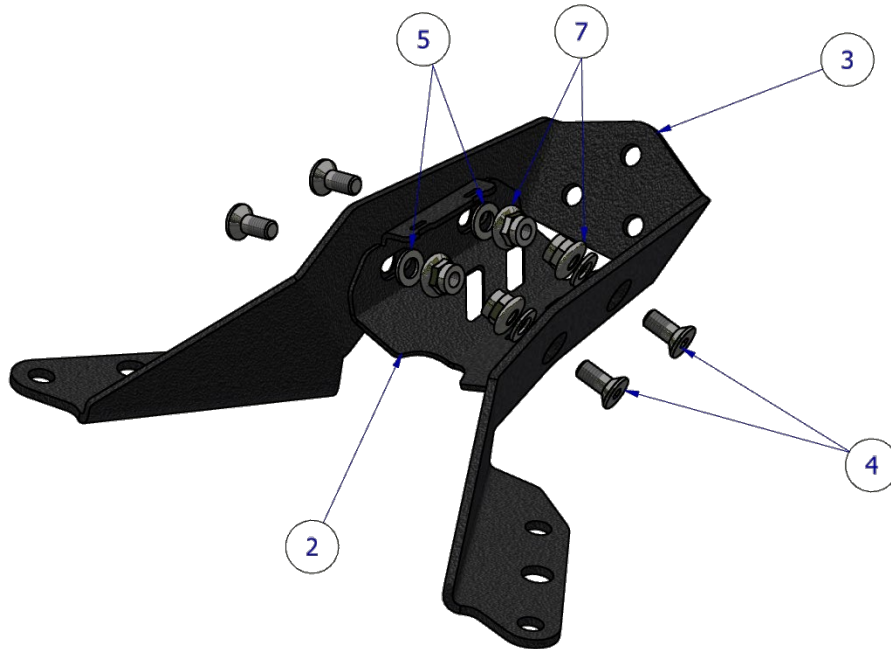

R&G

Unit 1, Shelley's Lane, East Worldham, Alton, Hampshire, GU34 3AQ

Tel: +44 (0)1420 89007 Fax: +44 (0)1420 87301 www.rg-racing.com Email: info@rg-racing.com



Abbildung 1



Abbildung 2

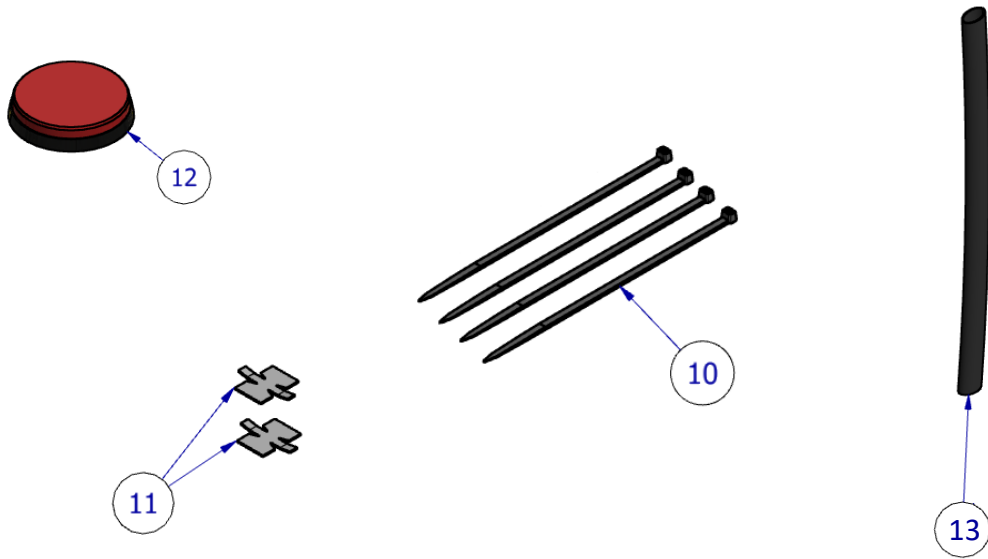

Abbildung 3



Abbildung 4

R&G



Abbildung 5

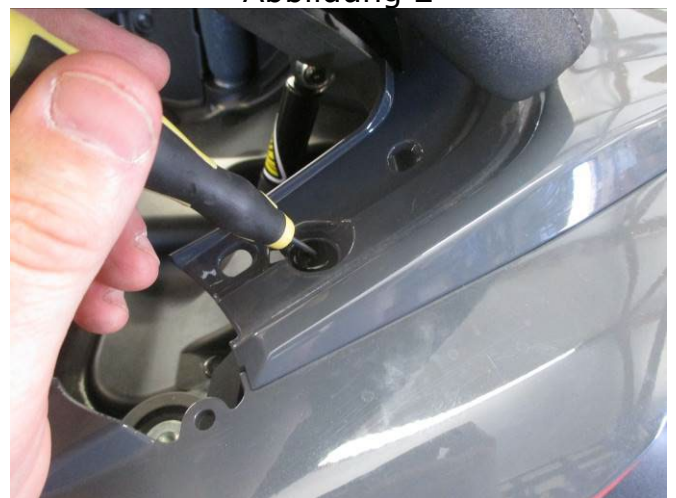

Abbildung 6



Abbildung 7



Abbildung 8



Abbildung 9



Abbildung 10

R&G



Abbildung 11



Abbildung 12

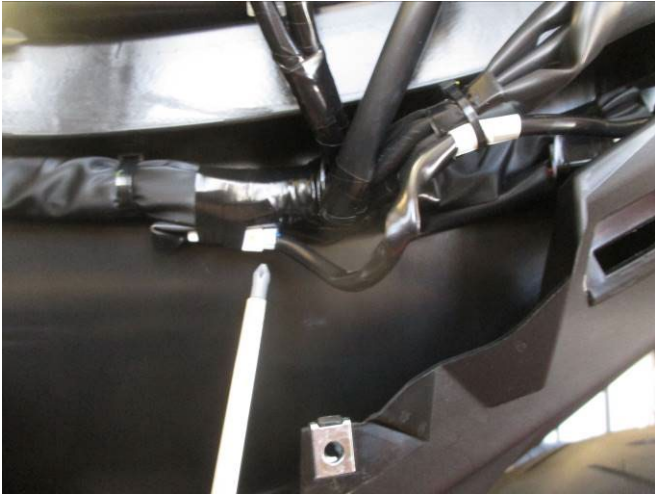

Abbildung 13

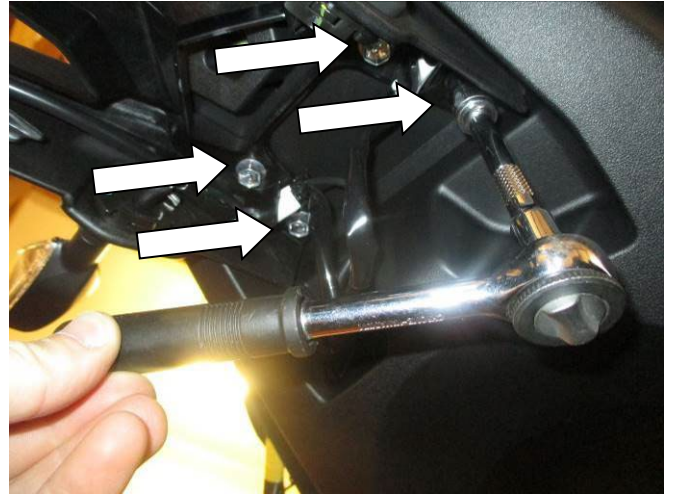

Abbildung 14



Abbildung 15

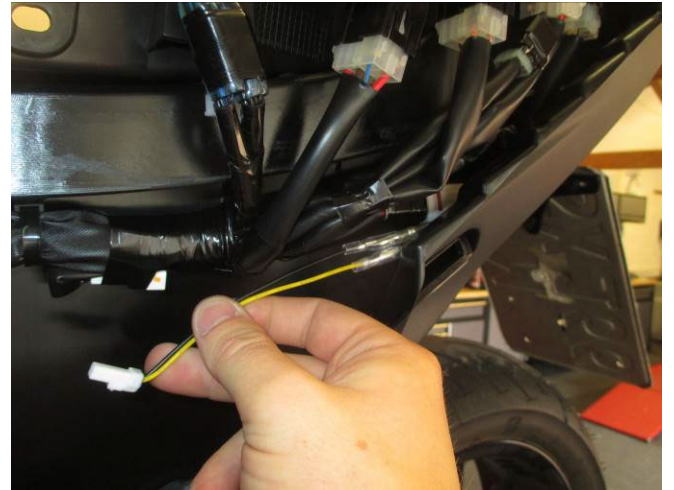

MONTAGEANLEITUNG

- Um den R&G Kennzeichenhalter montieren zu können, zuerst den Sitz hochklappen mit Hilfe des Schlüssels und Auslöseknopfs.
- Entfernen Sie die zwei Kunststoffabdeckungen am Haltegriff an der linken Seite des Motorrads wie in Abbildung 1 gekennzeichnet, und entfernen Sie die zwei Schrauben an der Unterseite. Entfernen Sie den Haltegriff vom Motorrad.
- Entfernen Sie das Kunststoffteil, welches die hinteren Verkleidungsteile verbindet, um Zugang zu den Schrauben darunter zu ermöglichen – siehe Abbildung 2.
- Die Gummi-Abdeckung lösen und entfernen, die in Abbildung 3 abgebildet ist, dann entfernen Sie die Schraube, die in Abbildung 4 abgebildet ist.
- Entfernen Sie die Schrauben, die in den Abbildungen 5-10 abgebildet sind. Danach können Sie das Seitenteil entfernen, welches in Abbildung 5 abgebildet ist. Dadurch werden Sie Zugang zur letzten Schraube bekommen, die entfernt werden muss, um anschließend das größere Seitenteil abzumontieren, sodass die Verkabelung zum original Kennzeichenhalter zugänglich ist.
- Trennen Sie den Verbinder, der in Abbildung 11 abgebildet ist und durchtrennen Sie sämtliche Kabelbinder, die den Kennzeichenhalter am Motorrad befestigen.
- Während Sie den Kennzeichenhalter stützen, entfernen Sie die 4 Sechskantschrauben an der Unterseite des original Kennzeichenhalters wie in Abbildung 12 abgebildet.
- Entfernen Sie den original Kennzeichenhalter vom Motorrad, die Kabel hierbei durch die Öffnung an der linken Seite des Motorrads führen, und komplett entfernen.
- Die Abdeckplatte (**Artikel 3**) an die Haupthalterung (**Artikel 2**) ansetzen und mit 4 x M5 Senkschrauben (**Artikel 4**), M5 Unterlegscheiben (**Artikel 5**) und M5 selbstsichernden Muttern (**Artikel 7**) in Position befestigen.
- Führen Sie die Kabel der neuen R&G Kennzeichenbeleuchtung (**Artikel 6**) durch die obere mittlere Öffnung im neuen Kennzeichenhalter (**Artikel 1**) und unter die Abdeckplatte (Artikel 3).
- Die Beleuchtung mit den M3 Unterlegscheiben und Muttern vom Kit befestigen wie in Abbildung 13 abgebildet.
- Eine Länge Schrumpfschlauch (**Artikel 13**) an den Kabeln anbringen und vorsichtig erwärmen, um sie passend zu schrumpfen.
- Montieren Sie die Lichtabdeckung und benutzen Sie eine kleine Menge Sekundenkleber, um sie in Position zu halten und somit das Licht ordnungsgemäß zu strahlen.
- Die Kabel für die Kennzeichenbeleuchtung mit den mitgelieferten Kabelbindern und Kabelclips verlegen und fixieren.
- Die Kennzeichenhalter-Einheit unten ans Heck ansetzen und die Kabel nach oben durch die kleine Öffnung (dort wo die original Verkabelung zuvor herausgenommen wurde) einfädeln. Den CON0014 Verbinder (**Artikel 14**) anbringen wie in Abbildung 14 abgebildet und den CON0014 Verbinder am original Kabelbaum anschließen.
- Nehmen Sie die vier M6 x 16mm Inbusschrauben (**Artikel 8**) und vier M6 Unterlegscheiben (**Artikel 9**) und montieren Sie sie an den vier Montageöffnungen am Kennzeichenhalter, bevor Sie sie in die Gewindeaufnahmen am Hilfsrahmen befestigen wie in Abbildung 15 abgebildet.
- Überprüfen Sie nun die Funktion der kompletten Beleuchtung. Falls diese nicht funktionieren sollten, einfach die Verbindungen untereinander tauschen.
- Stellen Sie sicher, dass die Kabel ordentlich hinter dem Verkleidungsteil verlegt sind mit den Kabelbindern (**Artikel 10**) und selbstklebenden Kabelclips (**Artikel 11**).
- Montieren Sie die Seitenverkleidungen sowie Haltegriffe wieder in umgekehrter Reihenfolge des vorherigen Abbaus.
- Montieren Sie das amtliche Kennzeichen wieder (Bohrungen im Kennzeichen evtl. notwendig).
- Entsprechend der gesetzlichen Vorschriften, den mitgelieferten Rückstrahler (**Artikel 12**) an die dafür vorgesehene Stelle anbringen.

R&G

Unit 1, Shelley's Lane, East Worldham, Alton, Hampshire, GU34 3AQ

Tel: +44 (0)1420 89007 Fax: +44 (0)1420 87301 www.rg-racing.com Email: info@rg-racing.com



- Überprüfen Sie die Funktion der Beleuchtung (Blinker und Kennzeichenhalterbeleuchtung) nochmal vor Gebrauch des Fahrzeuges.
- **WICHTIG: WENN EIN GROSSES KENNZEICHEN ZU WEIT NACH UNTEN MONTIERT WIRD, BESTEHT BEI SCHWERER LAST ODER DURCH GROSSE BODENWELLEN EIN GERINGES RISIKO, DASS DAS KENNZEICHEN AN DAS HINTERRAD STOSSEN KANN. ES LIEGT IN IHRER VERANTWORTUNG DIES ZU ÜBERPRÜFEN UND, WENN NOTWENDIG, VORZUBEUGENDE MASSNAHMEN ZU ERGREIFEN. DIE NICHTBEACHTUNG DIESES SICHERHEITSHINWEIS KANN ZU SCHWEREN VERLETZUNGEN FÜHREN.**

AUSGABE 1 26/10/2022 (MH)

CONSUMER NOTICE

The catalogue description and any exhibition of samples are only broad indications of the Products and R&G may make design changes which do not diminish their performance or visual appeal and supplying them in such state shall conform to the order. The Buyer acknowledges no representation or warranty (other than as to title) has been given or will apply to the Products other than those in R&G's order or confirmation and the Buyer confirms it has chosen the Products as being of merchantable quality and suitable for its particular purposes. Where R&G fits the Products or undertakes other services it shall exercise reasonable skill and care and rectify any fault free of charge unless the workmanship has been disturbed. The Buyer is responsible for ensuring that the warranty on the motorcycle is not affected by the fitting of the Products. On return of any defective Products R&G shall at its option either supply a replacement or refund the purchase money but shall not be liable if the Products have been modified or used or maintained otherwise than in accordance with R&G's or manufacturer's instructions and good engineering practice or if the defect arises from accident or neglect. Other than identified above and subject to R&G not limiting its liability for causing death and personal injury, it shall not be liable for indirect or consequential loss and otherwise its liability shall be limited to the amounts paid by the Buyer for the Products or the fitting or service concerned. These terms do not affect the Buyer's statutory rights.

R&G RACING RETURNS POLICY (NON-FAULTY GOODS)

Returns must be pre-authorized (if not pre-authorized the return will be rejected). Goods may only be returned direct to us if they were purchased direct from us (customer must prove if necessary). Otherwise to be returned to original vendor. Goods must be in re-sellable condition, in the opinion of R&G Racing. All returns are subject to a 25% restocking and handling fee (25% of the gross value exc. P&P – at the prevailing price at time of purchase). The customer must pay any and all carriage charges. No returns of discontinued products, unless within 14 days of purchase. This policy does not affect your statutory rights and does not refer to faulty goods.

R&G

Unit 1, Shelley's Lane, East Worldham, Alton, Hampshire, GU34 3AQ

Tel: +44 (0)1420 89007 Fax: +44 (0)1420 87301 www.rg-racing.com Email: info@rg-racing.com