



**FITTING INSTRUCTIONS FOR FP0249 FORK PROTECTORS
TO FIT APRILIA RS660 + TUONO 660 2021-**



This kit contains the items pictured and labelled over page.

Some parts may be shown for clarity of instructions only.

Do not proceed until you are sure all parts are present.

Please read all instructions before proceeding.

**IF IN ANY DOUBT WHEN FITTING OUR PRODUCTS, CONSULT ONE OF OUR DEALERS
OR HAVE FITTED BY A QUALIFIED TECHNICIAN.**

Please note that the way the kit is packed does not necessarily represent the way of mounting to the bike.

In the event of rubber washers being used to hold components onto bolts, these rubber washers can be thrown away.

DIGITAL COPIES OF THESE INSTRUCTIONS ARE AVAILABLE FROM

WWW.RG-RACING.COM

R&G

Unit 1, Shelley's Lane, East Worldham, Alton, Hampshire, GU34 3AQ

Tel: +44 (0)1420 89007 Fax: +44 (0)1420 87301 www.rg-racing.com Email: info@rg-racing.com



<u>TOOLS REQUIRED</u>	<u>GENERAL TORQUE SETTINGS</u>
<ul style="list-style-type: none"> • Socket Set to Include 2 x 13mm sockets and wrenches. • Thread locking compound 	<p>M4 BOLT = 8Nm</p> <p>M5 BOLT = 12Nm</p> <p>M6 BOLT = 15Nm</p> <p>M8 BOLT = 20Nm</p> <p>M10 BOLT = 40Nm</p> <p>M12 BOLT = 40Nm</p>

LEGEND

ITEM No.	DESCRIPTION	QTY
ITEM 1	SB156 SPINDLE BAR (M8 x 345mm LONG)	1
ITEM 2	B0445 M8 CRASH PROTECTOR (BOTH SIDES)	2
ITEM 3	S1346 LEFT-HAND-SIDE CRASH PROTECTOR SPACER	1
ITEM 4	S1347 RIGHT-HAND-SIDE CRASH PROTECTOR SPACER	1
ITEM 5	M8 x 19mm WASHER	2
ITEM 6	M8 NYLOC NUT	2

R&G

Unit 1, Shelley's Lane, East Worldham, Alton, Hampshire, GU34 3AQ

Tel: +44 (0)1420 89007 Fax: +44 (0)1420 87301 www.rg-racing.com Email: info@rg-racing.com



ASSEMBLY DIAGRAM

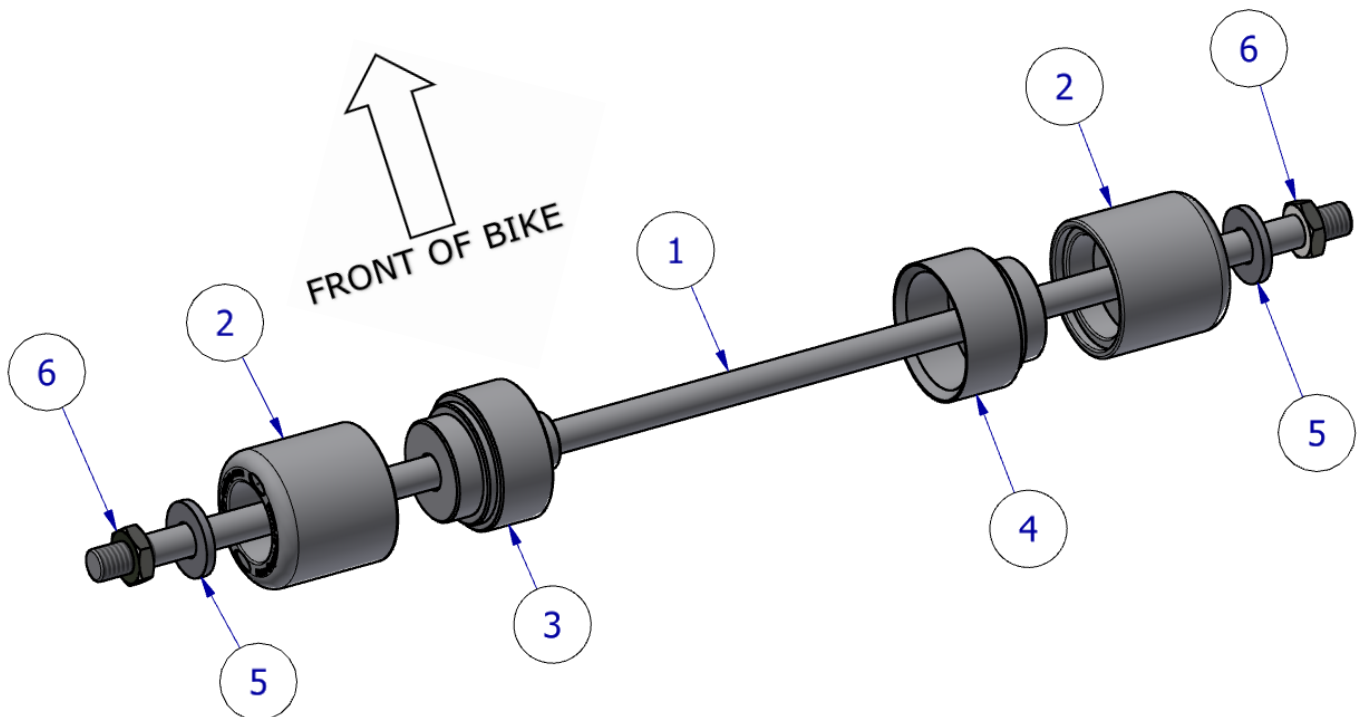

FITTING INSTRUCTIONS

- Fit one nut (**item 6**) and one washer (**item 5**) to the spindle bar (**item 1**), engaging the nut so the plastic insert of the nut is fully engaged so the bar protrudes by 1 or 2 threads. It is recommended to use a small amount of superglue or Loctite to fix this nut as this will aid when tightening the opposite side later.
- Place one M8 washer (**item 5**) over the spindle bar to meet the nut.
- Place one crash protector (**item 2**) over the spindle bar as shown in the assembly diagram so that the nut and washer sit into the recessed bore of the crash protector.
- Place the RHS spacer (**item 3**) over the spindle in the orientation shown in the assembly diagram, the larger diameter should sit into the crash protector.
- Feed spindle-bar and crash protector assembly into the front wheel spindle from the left-hand side so the smaller diameter of the spacer sits into the internal hex of the spindle.
- Place the RHS spacer (**Item 4**) over the exposed thread on the right-hand side so it covers the protruding area of the RHS fork.
- Place remaining crash protector (**item 2**) over exposed end of spindle bar so that it covers the spacer as shown in the assembly diagram.
- Fit the remaining washer (**item 5**) and nut (**item 6**) from kit onto the exposed thread.

R&G

Unit 1, Shelley's Lane, East Worldham, Alton, Hampshire, GU34 3AQ

Tel: +44 (0)1420 89007 Fax: +44 (0)1420 87301 www.rg-racing.com Email: info@rg-racing.com



- Tighten the nut on both sides evenly using two 13mm sockets and ensure that the plastic insert of both nuts is fully engaged, and the protruding threads are equal on both sides.
- Do not overtighten – the nyloc nuts will hold it tight.
- Check the fork protectors are secure and held firmly against the spacers and do not spin freely.
- After riding the bike, check the tightness of the nuts regularly (e.g. when cleaning the bike).

ISSUE 1 07/09/2021 (DM)

CONSUMER NOTICE

The catalogue description and any exhibition of samples are only broad indications of the Products and R&G may make design changes which do not diminish their performance or visual appeal and supplying them in such state shall conform to the order. The Buyer acknowledges no representation or warranty (other than as to title) has been given or will apply to the Products other than those in R&G's order or confirmation and the Buyer confirms it has chosen the Products as being of merchantable quality and suitable for its particular purposes. Where R&G fits the Products or undertakes other services it shall exercise reasonable skill and care and rectify any fault free of charge unless the workmanship has been disturbed. The Buyer is responsible for ensuring that the warranty on the motorcycle is not affected by the fitting of the Products. On return of any defective Products R&G shall at its option either supply a replacement or refund the purchase money but shall not be liable if the Products have been modified or used or maintained otherwise than in accordance with R&G's or manufacturer's instructions and good engineering practice or if the defect arises from accident or neglect. Other than identified above and subject to R&G not limiting its liability for causing death and personal injury, it shall not be liable for indirect or consequential loss and otherwise its liability shall be limited to the amounts paid by the Buyer for the Products or the fitting or service concerned. These terms do not affect the Buyer's statutory rights.

R&G RACING RETURNS POLICY (NON-FAULTY GOODS)

Returns must be pre-authorized (if not pre-authorized the return will be rejected). Goods may only be returned direct to us if they were purchased direct from us (customer must prove if necessary). Otherwise to be returned to original vendor. Goods must be in re-sellable condition, in the opinion of R&G Racing. All returns are subject to a 25% restocking and handling fee (25% of the gross value exc. P&P – at the prevailing price at time of purchase). The customer must pay any and all carriage charges. No returns of discontinued products, unless within 14 days of purchase. This policy does not affect your statutory rights and does not refer to faulty goods.

R&G

Unit 1, Shelley's Lane, East Worldham, Alton, Hampshire, GU34 3AQ

Tel: +44 (0)1420 89007 Fax: +44 (0)1420 87301 www.rg-racing.com Email: info@rg-racing.com



**NOTICE DE MONTAGE POUR FP0249 PROTECTIONS FOURCHE
POUR APRILIA RS660 + TUONO 660 2021-**



CE KIT CONTIENT LES ARTICLES ILLUSTRÉS ET ÉTIQUETES SUR LA PAGE.

CERTAINES PARTIES PEUVENT ÊTRE PRÉSENTES UNIQUEMENT POUR LA CLARTÉ DES INSTRUCTIONS.

NE PAS PROCÉDER AU MONTAGE TANT QUE VOUS N'ÊTES PAS SÛR QUE TOUTES LES PIÈCES SOIENT PRÉSENTES.

VEUILLEZ LIRE TOUTES LES INSTRUCTIONS AVANT DE CONTINUER.

EN CAS DE DOUTE LORS DU MONTAGE DE NOS PRODUITS, CONSULTEZ UN DE NOS REVENDEURS OU FAITES APPEL À UN TECHNICIEN QUALIFIÉ.

VEUILLEZ NOTER QUE LA FAÇON DONT LE KIT EST EMBALLÉ NE REPRÉSENTE PAS NECESSAIREMENT LA MANIÈRE DE LE MONTER SUR LA MOTO.

SI DES RONDELLES EN CAOUTCHOUC SONT UTILISÉES POUR MAINTENIR LES COMPOSANTS SUR LES BOULONS, ELLES PEUVENT ÊTRE JETÉES.

NOTICE DISPONIBLE AU TÉLÉCHARGEMENT SUR : WWW.RG-RACING.COM

R&G

Unit 1, Shelley's Lane, East Worldham, Alton, Hampshire, GU34 3AQ
Tel: +44 (0)1420 89007 Fax: +44 (0)1420 87301 www.rg-racing.com Email: info@rg-racing.com



<u>OUTLS REQUIS</u>	<u>VALEURS DE SERRAGE</u>
<ul style="list-style-type: none"> • Clé à cliquet + douilles 2 x 13mm. • Thread locking compound 	M4 BOULON = 8Nm M5 BOULON = 12Nm M6 BOULON = 15Nm M8 BOULON = 20Nm M10 BOULON = 40Nm M12 BOULON = 40Nm

LÉGENDE

ARTICLE No.	DESCRIPTION	QTÉ
ARTICLE 1	SB156 BARRE (M8 x 345mm DE LONG)	1
ARTICLE 2	B0445 M8 PROTECTION CRASH (DES 2 CÔTÉS)	2
ARTICLE 3	S1346 ENTRETOISE DE PROTECTION CRASH CÔTÉ GAUCHE	1
ARTICLE 4	S1347 ENTRETOISE DE PROTECTION CRASH CÔTÉ DROIT	1
ARTICLE 5	M8 x 19mm RONDELLE	2
ARTICLE 6	M8 ÉCROU	2

R&G

Unit 1, Shelley's Lane, East Worldham, Alton, Hampshire, GU34 3AQ
 Tel: +44 (0)1420 89007 Fax: +44 (0)1420 87301 www.rg-racing.com Email: info@rg-racing.com



SCHÉMA D'ENSEMBLE

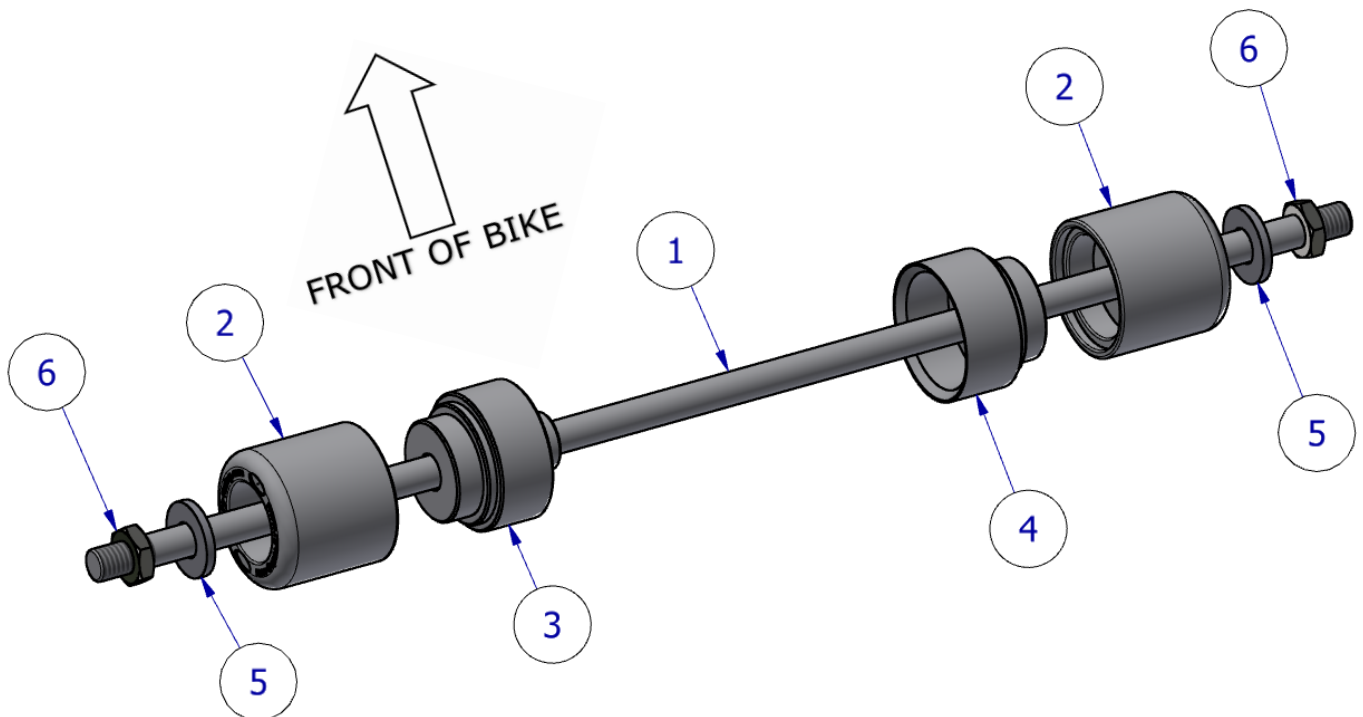

NOTICE DE MONTAGE

- Monter un écrou (article 6) et une rondelle (article 5) sur la barre (article 1), en engageant l'écrou de sorte que l'insert en plastique de l'écrou soit complètement engagé de sorte que la barre dépasse de 1 ou 2 filets. Il est recommandé d'utiliser une petite quantité de superglue ou de Loctite pour fixer cet écrou car cela facilitera le serrage ultérieur du côté opposé.
- Placer une rondelle M8 (article 5) sur la barre pour jusqu'à l'écrou.
- Placer un pare-chocs (article 2) sur la barre comme indiqué sur le schéma de montage de sorte que l'écrou et la rondelle s'emboîtent dans l'alésage en retrait de la protection.
- Placez l'entretoise côté droit (article 3) sur l'axe dans l'orientation indiquée sur le schéma de montage, le plus grand diamètre doit s'insérer dans la protection crash.
- Introduisez l'ensemble barre et protection crash dans le moyeu de la roue avant par le côté gauche de sorte que le plus petit diamètre de l'entretoise s'insère dans l'hexagone interne du moyeu.
- Placer l'entretoise côté droit (article 4) sur le filetage exposé du côté droit de manière à ce qu'elle recouvre la zone dépassant de la fourche côté droit.

R&G

Unit 1, Shelley's Lane, East Worldham, Alton, Hampshire, GU34 3AQ
 Tel: +44 (0)1420 89007 Fax: +44 (0)1420 87301 www.rg-racing.com Email: info@rg-racing.com



- Placez l'autre protection crash (article 2) sur l'extrémité exposée de la barre de manière à ce qu'elle recouvre l'entretoise comme indiqué sur le schéma d'assemblage.
- Monter la rondelle (article 5) et l'écrou (article 6) restants du kit sur le filetage exposé.
- Serrez uniformément l'écrou des deux côtés à l'aide de deux douilles de 13 mm et assurez-vous que l'insert en plastique des deux écrous soit complètement engagé et que les filetages saillants soient égaux des deux côtés.
- Ne pas trop serrer – les écrous nyloc maintiennent l'ensemble
- Vérifiez que les protections fourche soient bien fixées et maintenues fermement contre les entretoises et ne tournent pas librement.
- Après avoir utilisé la moto, vérifiez régulièrement le serrage des écrous (par exemple lors du nettoyage de la moto).

ISSUE 1 07/09/2021 (DM)

CONSUMER NOTICE

The catalogue description and any exhibition of samples are only broad indications of the Products and R&G may make design changes which do not diminish their performance or visual appeal and supplying them in such state shall conform to the order. The Buyer acknowledges no representation or warranty (other than as to title) has been given or will apply to the Products other than those in R&G's order or confirmation and the Buyer confirms it has chosen the Products as being of merchantable quality and suitable for its particular purposes. Where R&G fits the Products or undertakes other services it shall exercise reasonable skill and care and rectify any fault free of charge unless the workmanship has been disturbed. The Buyer is responsible for ensuring that the warranty on the motorcycle is not affected by the fitting of the Products. On return of any defective Products R&G shall at its option either supply a replacement or refund the purchase money but shall not be liable if the Products have been modified or used or maintained otherwise than in accordance with R&G's or manufacturer's instructions and good engineering practice or if the defect arises from accident or neglect. Other than identified above and subject to R&G not limiting its liability for causing death and personal injury, it shall not be liable for indirect or consequential loss and otherwise its liability shall be limited to the amounts paid by the Buyer for the Products or the fitting or service concerned. These terms do not affect the Buyer's statutory rights.

R&G RACING RETURNS POLICY (NON-FAULTY GOODS)

Returns must be pre-authorized (if not pre-authorized the return will be rejected). Goods may only be returned direct to us if they were purchased direct from us (customer must prove if necessary). Otherwise to be returned to original vendor. Goods must be in re-sellable condition, in the opinion of R&G Racing. All returns are subject to a 25% restocking and handling fee (25% of the gross value exc. P&P – at the prevailing price at time of purchase). The customer must pay any and all carriage charges. No returns of discontinued products, unless within 14 days of purchase. This policy does not affect your statutory rights and does not refer to faulty goods.

R&G

Unit 1, Shelley's Lane, East Worldham, Alton, Hampshire, GU34 3AQ

Tel: +44 (0)1420 89007 Fax: +44 (0)1420 87301 www.rg-racing.com Email: info@rg-racing.com