



FITTING INSTRUCTIONS FOR CP0537 AERO CRASH PROTECTORS
BMW S1000R (ALL VARIANTS) 2021-



THIS KIT CONTAINS THE ITEMS PICTURED AND LABELLED OVER PAGE.

SOME PARTS MAY BE SHOWN FOR CLARITY OF INSTRUCTIONS ONLY.

DO NOT PROCEED UNTIL YOU ARE SURE ALL PARTS ARE PRESENT.

PLEASE READ ALL INSTRUCTIONS BEFORE PROCEEDING.

**IF IN ANY DOUBT WHEN FITTING OUR PRODUCTS, CONSULT ONE OF OUR DEALERS
OR HAVE FITTED BY A QUALIFIED TECHNICIAN.**

PLEASE NOTE THAT THE WAY THE KIT IS PACKED DOES NOT NECESSARILY REPRESENT THE WAY OF
MOUNTING TO THE BIKE.

IN THE EVENT OF RUBBER WASHERS BEING USED TO HOLD COMPONENTS ONTO BOLTS,
THESE RUBBER WASHERS CAN BE THROWN AWAY.

DIGITAL COPIES OF THESE INSTRUCTIONS ARE AVAILABLE FROM:

WWW.RG-RACING.COM

R&G Racing
Unit 1, Shelley's Lane, East Worldham, Alton, Hampshire, GU34 3AQ
Tel: +44 (0)1420 89007 Fax: +44 (0)1420 87301 www.rg-racing.com Email: info@rg-racing.com



<u>TOOLS REQUIRED</u>	<u>GENERAL TORQUE SETTINGS</u>
<ul style="list-style-type: none"> • 17mm & 19mm A/F SOCKET & WRENCH • 8mm Allen key • T45 & T20 Torx drive • TORQUE WRENCH (UP TO 40Nm) • Suitable bike engine support jack 	M4 BOLT = 8Nm M5 BOLT = 12Nm M6 BOLT = 15Nm M8 BOLT = 20Nm M10 BOLT = 40Nm M12 BOLT = 40Nm

LEGEND

ITEM NO.	DESCRIPTION	QTY
ITEM 1	M0688 - MOUNTING BRACKET LHS	1
ITEM 2	M0689 - MOUNTING BRACKET RHS	1
ITEM 3	S1396 - BRACKET MOUNTING SPACERS LHS	2
ITEM 4	S1397 - BRACKET MOUNTING SPACERS RHS TOP	1
ITEM 5	S1398 - BRACKET MOUNTING SPACERS RHS BOT	1
ITEM 6	B0063 - CRASH PROTECTORS (BOTH SIDES)	2
ITEM 7	BC0002 - CRASH PROTECTOR CAPS	2
ITEM 8	M10x1.50x75mm LONG 8.8 GRADE HEX HEAD BOLTS	2
ITEM 9	BOLT0008 - M10x1.50x65mm LONG COUNTERSUNK BOLTS	2
ITEM 10	NC0001 - M10 RUBBER NUT CAPS (BOTH SIDES)	2
ITEM 11	NC0009 - M8 PLASTIC FLAT CAPS (BOTH SIDES)	2
ITEM 12	M10x1.25x40mm LONG HEX HEAD BOLTS	2
ITEM 13	M10 WASHERS	2
ITEM 14	LW0001 - M12 LOCKING WASHERS	2

R&G Racing

Unit 1, Shelley's Lane, East Worldham, Alton, Hampshire, GU34 3AQ

Tel: +44 (0)1420 89007 Fax: +44 (0)1420 87301 www.rg-racing.com Email: info@rg-racing.com



AERO-STYLE CRASH PROTECTOR ORIENTATION



LHS EXPLODED ASSEMBLY VIEW

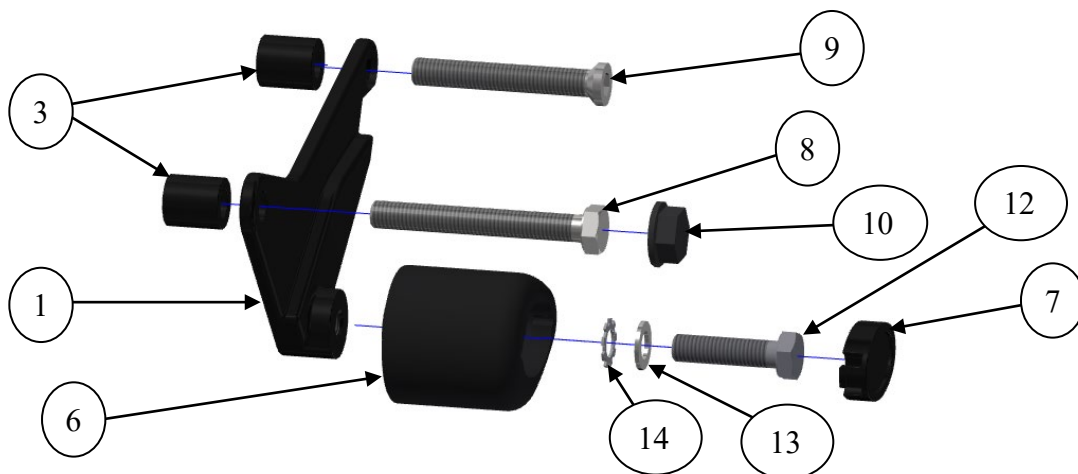

RHS EXPLODED ASSEMBLY VIEW

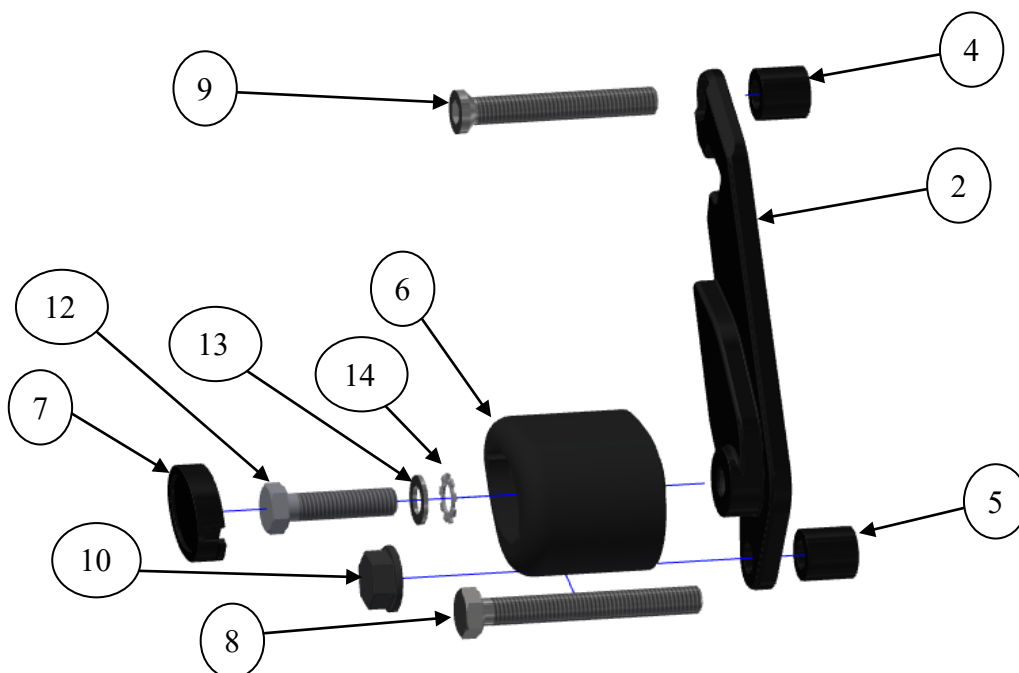



FITTING PICTURES



Picture 1



Picture 2



Picture 3



Picture 4



Picture 5



Picture 6



Picture 7

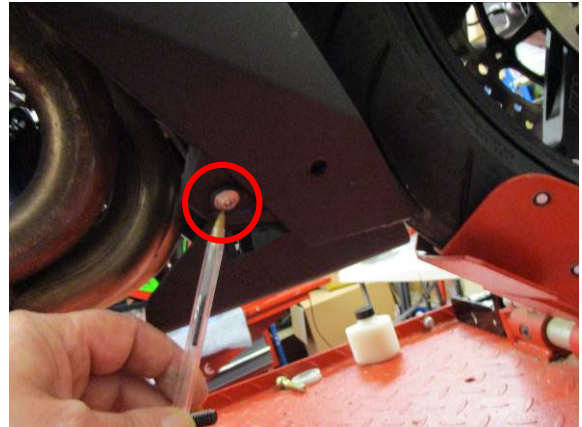

Picture 8

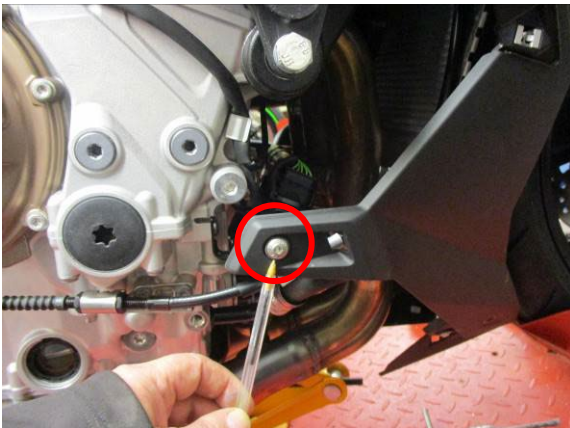

Picture 9

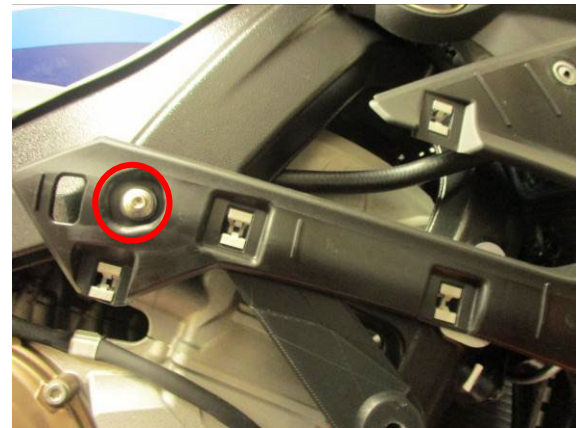

Picture 10



Picture 11



Picture 12



Picture 13

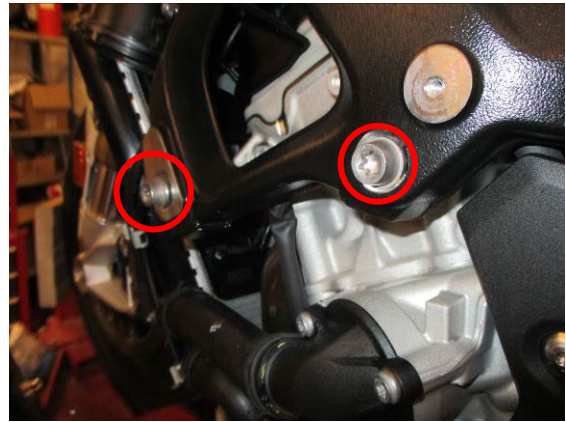

Picture 14



Picture 15

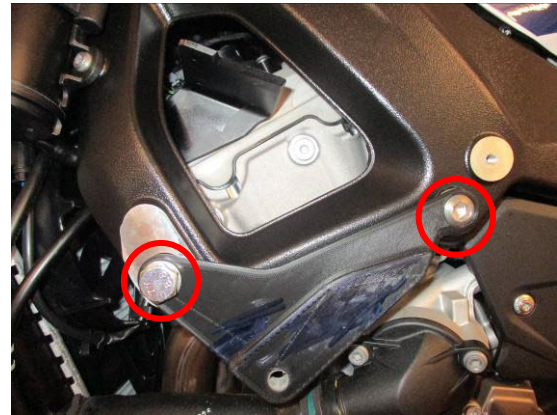

Picture 16

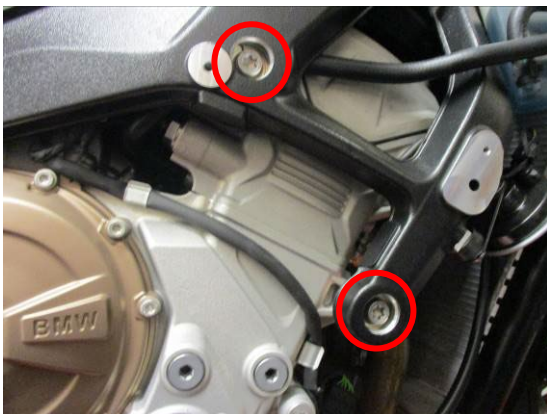

Picture 17

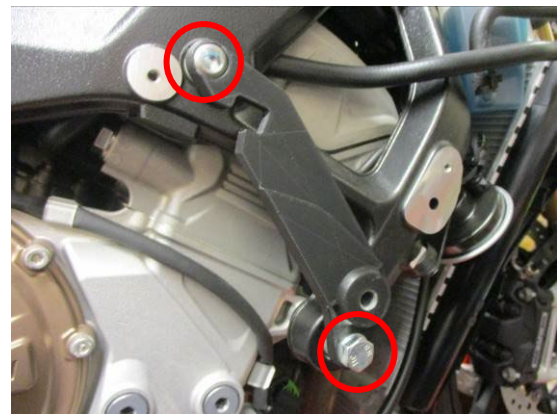

Picture 18



Picture 19



Picture 20



Picture 21



Picture 22



Picture 23



Picture 24



FITTING INSTRUCTIONS

BEFORE REMOVING ENGINE BOLTS, ENSURE THE BIKE IS UPRIGHT AND SUPPORTED BY A SUITABLE ENGINE STAND OR JACK PLACED UNDER THE SUMP OF THE MOTORBIKE TO SUPPORT THE WEIGHT OF THE ENGINE, THIS WILL PREVENT THE ENGINE FROM MOVING DURING FITTING.

FAIRING REMOVAL

- Begin by removing the lower cover piece. This can be removed by removing the screw shown in **Picture 1**. The white cover then needs to be popped outwards and pulled backwards as shown in **Picture 2** to be removed. Repeat this process for both sides.
- Next the upper fairing cover pieces need to be removed. Start by removing the 3 screws shown in **Pictures 3 & 4** on both sides.
- Now the cover piece can be gently pulled away. Manipulate the cover so that the clips pop out one by one until the cover is free and can be removed on both sides as shown in **Pictures 5, 6 & 7**.
- The main fairing pieces now need to be removed to expose the mounting bolts for the crash protector kit.
- Remove the screw shown in **Pictures 8, 9 & 10** in both sides.
- Next, the plastic protrusion in the fairing, near to the BMW badge can be pulled free from the rubber grommet on both sides as shown in **Picture 11**.
- Finally, the last clip can be pulled free from the lower portion of the fairing as shown in **Picture 12**. The remaining fairing pieces can now be removed on both sides.

LHS BRACKET INSTALLATION

- Before removing the engine mounting bolts, ensure that the engine is supported with a jack or engine stand as shown in **Picture 13**.
- Remove the 2 bolts shown in **Picture 14**.
- Insert the 2 spacers (ITEM 3) into the holes left by the 2 bolts which have just been removed.
- Offer the LHS mounting bracket (ITEM 1) into position and insert the 2 bolts (ITEMS 8 & 9) into position as shown in **Picture 15**.
- Tighten the 2 bolts to the specified torque setting (as shown in **Picture 16**) as specified in the BMW service manual.

RHS BRACKET INSTALLATION

- Before removing the engine mounting bolts, ensure that the engine is supported with a jack or engine stand as shown in **Picture 13**.
- Remove the 2 bolts shown in **Picture 17**.
- Insert the 2 spacers (ITEMS 4 & 5) into the holes left by the 2 bolts which have just been removed.
- Offer the RHS mounting bracket (ITEM 2) into position and insert the 2 bolts (ITEMS 8 & 9) into position as shown in **Picture 18**.
- Tighten the 2 bolts to the specified torque setting as specified in the BMW service manual.

R&G Racing

Unit 1, Shelley's Lane, East Worldham, Alton, Hampshire, GU34 3AQ

Tel: +44 (0)1420 89007 Fax: +44 (0)1420 87301 www.rg-racing.com Email: info@rg-racing.com



BOBBIN INSTALLATION

- Before attaching the crash bobbins, re-assemble the fairings to the bike by reversing the steps described in the FAIRING REMOVAL section. This will leave the mounting bosses for the bobbins exposed as shown in **Pictures 19 & 20**.
- (Note that a black bobbin has been used for the LHS and a white bobbin for the RHS for illustration purposes.)
- Insert the locking washers (ITEM 14), plain washers (ITEM 13), then bobbin bolts (ITEM 12) into the bobbins and tighten to the bosses as shown in **Pictures 21 & 22** to 40Nm.
- Finally clip on the bobbin caps to hide the bolts as shown in **Pictures 23 & 24**.

ISSUE 1 – 01/02/2022 (WW)

CONSUMER NOTICE

The catalogue description and any exhibition of samples are only broad indications of the Products and R&G may make design changes which do not diminish their performance or visual appeal and supplying them in such state shall conform to the order. The Buyer acknowledges no representation or warranty (other than as to title) has been given or will apply to the Products other than those in R&G's order or confirmation and the Buyer confirms it has chosen the Products as being of merchantable quality and suitable for its particular purposes. Where R&G fits the Products or undertakes other services it shall exercise reasonable skill and care and rectify any fault free of charge unless the workmanship has been disturbed. The Buyer is responsible for ensuring that the warranty on the motorcycle is not affected by the fitting of the Products. On return of any defective Products R&G shall at its option either supply a replacement or refund the purchase money but shall not be liable if the Products have been modified or used or maintained otherwise than in accordance with R&G's or manufacturer's instructions and good engineering practice or if the defect arises from accident or neglect. Other than identified above and subject to R&G not limiting its liability for causing death and personal injury, it shall not be liable for indirect or consequential loss and otherwise its liability shall be limited to the amounts paid by the Buyer for the Products or the fitting or service concerned. These terms do not affect the Buyer's statutory rights.

R&G RACING RETURNS POLICY (NON-FAULTY GOODS)

Returns must be pre-authorized (if not pre-authorized the return will be rejected). Goods may only be returned direct to us if they were purchased direct from us (customer must prove if necessary). Otherwise, to be returned to original vendor. Goods must be in re-sellable condition, in the opinion of R&G Racing. All returns are subject to a 25% restocking and handling fee (25% of the gross value exc. P&P – at the prevailing price at time of purchase). The customer must pay any and all carriage charges. No returns of discontinued products, unless within 14 days of purchase. This policy does not affect your statutory rights and does not refer to faulty goods.

R&G Racing

Unit 1, Shelley's Lane, East Worldham, Alton, Hampshire, GU34 3AQ

Tel: +44 (0)1420 89007 Fax: +44 (0)1420 87301 www.rg-racing.com Email: info@rg-racing.com



NOTICE DE MONTAGE POUR CP0537 PROTECTIONS CRASH
BMW S1000R (toutes variantes) 2021-



CE KIT CONTIENT LES ARTICLES ILLUSTRÉS ET ÉTIQUETÉS SUR LA PAGE.

CERTAINES PARTIES PEUVENT ÊTRE PRÉSENTES UNIQUEMENT POUR LA CLARTÉ DES INSTRUCTIONS.

NE PAS PROCÉDER AU MONTAGE TANT QUE VOUS N'ÊTES PAS SÛR QUE TOUTES LES PIÈCES SOIENT PRÉSENTES.

VEUILLEZ LIRE TOUTES LES INSTRUCTIONS AVANT DE CONTINUER.

EN CAS DE DOUTE LORS DU MONTAGE DE NOS PRODUITS, CONSULTEZ UN DE NOS REVENDEURS OU FAITES APPEL À UN TECHNICIEN QUALIFIÉ.

VEUILLEZ NOTER QUE LA FAÇON DONT LE KIT EST EMBALLÉ NE REPRÉSENTE PAS NECESSAIREMENT LA MANIÈRE DE LE MONTER SUR LA MOTO.

SI DES RONDELLES EN CAOUTCHOUC SONT UTILISÉES POUR MAINTENIR LES COMPOSANTS SUR LES BOULONS, ELLES PEUVENT ÊTRE JETÉES.

NOTICE DISPONIBLE AU TÉLÉCHARGEMENT SUR : WWW.RG-RACING.COM

R&G Racing

Unit 1, Shelley's Lane, East Worldham, Alton, Hampshire, GU34 3AQ

Tel: +44 (0)1420 89007 Fax: +44 (0)1420 87301 www.rg-racing.com Email: info@rg-racing.com



<u>OUTILS REQUIS</u>	<u>VALEURS DE SERRAGE</u>
<ul style="list-style-type: none"> • CLÉ À CLIQUET + DOUILLES 17mm & 19mm • CLÉ ALLEN 8mm • CLÉS TORX T45 & T20 • CLÉ DYNAMOMÉTRIQUE (À 40Nm) • PRISE ADAPTÉE POUR SUPPORTER LE MOTEUR 	M4 BOULON = 8Nm M5 BOULON = 12Nm M6 BOULON = 15Nm M8 BOULON = 20Nm M10 BOULON = 40Nm M12 BOULON = 40Nm

LÉGENDE

ARTICLE NO.	DESCRIPTION	QTÉ
ARTICLE 1	M0688 – SUPPORT DE MONTAGE CÔTÉ GAUCHE	1
ARTICLE 2	M0689 - SUPPORT DE MONTAGE CÔTÉ DROIT	1
ARTICLE 3	S1396 – ENTRETOISE DE SUPPORT DE MONTAGE CÔTÉ GAUCHE	2
ARTICLE 4	S1397 - ENTRETOISE DE SUPPORT DE MONTAGE CÔTÉ SUPÉRIEUR DROIT	1
ARTICLE 5	S1398 - ENTRETOISES DE MONTAGE DU SUPPORT CÔTÉ DROIT	1
ARTICLE 6	B0063 – PROTECTIONS CRASH (DES 2 CÔTÉS)	2
ARTICLE 7	BC0002 – CAPUCHONS DE PROTECTION CRASH	2
ARTICLE 8	M10x1.50x75mm 8.8 BOULONS	2
ARTICLE 9	BOLT0008 - M10x1.50x65mm BOULONS	2
ARTICLE 10	NC0001 - M10 CAPUCHONS (DES 2 CÔTÉS)	2
ARTICLE 11	NC0009 - M8 CAPUCHONS PLATS (DES 2 CÔTÉS)	2
ARTICLE 12	M10x1.25x40mm BOULONS	2
ARTICLE 13	M10 RONDELLES	2
ARTICLE 14	LW0001 - M12 RONDELLES DE BLOCAGE	2

R&G Racing

Unit 1, Shelley's Lane, East Worldham, Alton, Hampshire, GU34 3AQ

Tel: +44 (0)1420 89007 Fax: +44 (0)1420 87301 www.rg-racing.com Email: info@rg-racing.com



ORIENTATION DE LA PROTECTION CRASH



VUE D'ENSEMBLE CÔTÉ GAUCHE

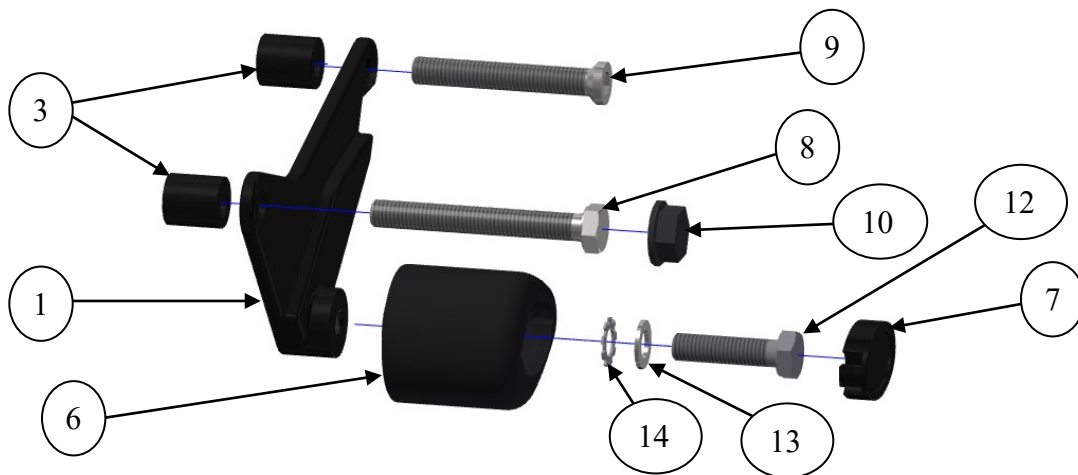

VUE D'ENSEMBLE CÔTÉ DROIT

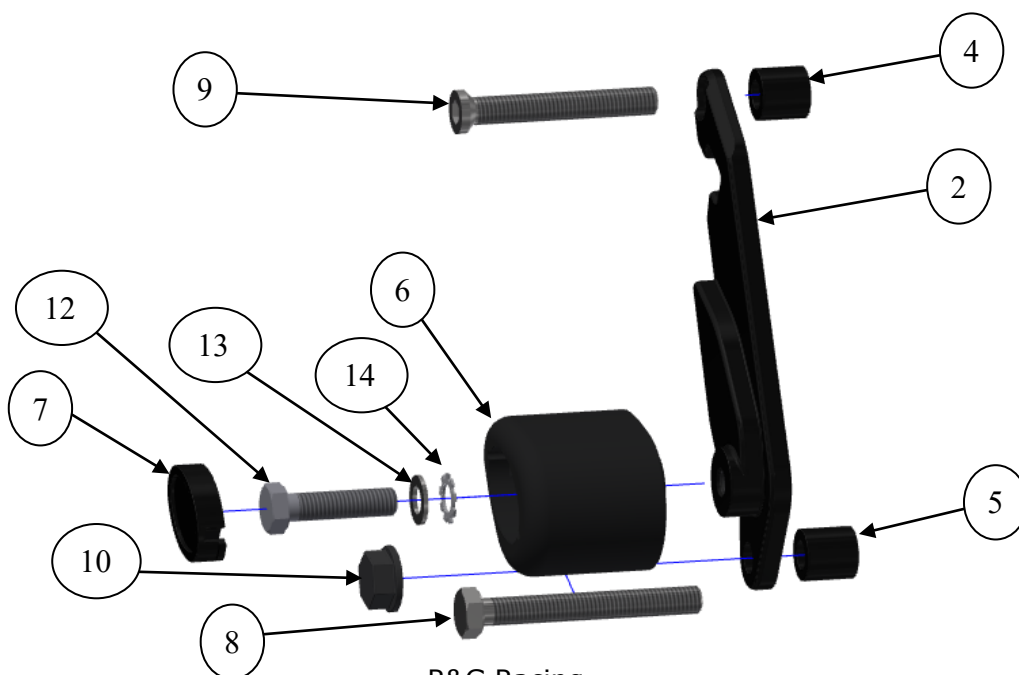

R&G Racing

Unit 1, Shelley's Lane, East Worldham, Alton, Hampshire, GU34 3AQ

Tel: +44 (0)1420 89007 Fax: +44 (0)1420 87301 www.rg-racing.com Email: info@rg-racing.com



PHOTOS DE MONTAGE

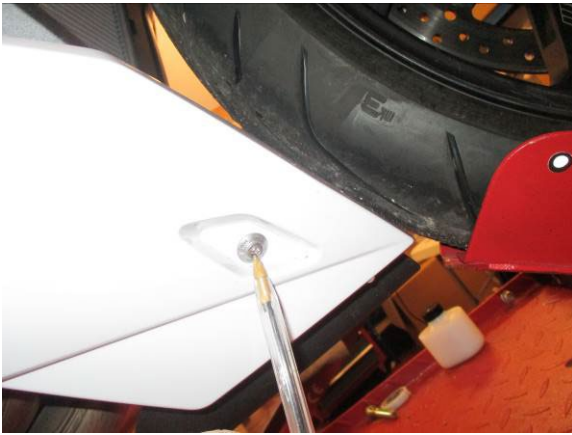

Photo 1



Photo 2



Photo 3



Photo 4



Photo 5



Photo 6



Photo 7

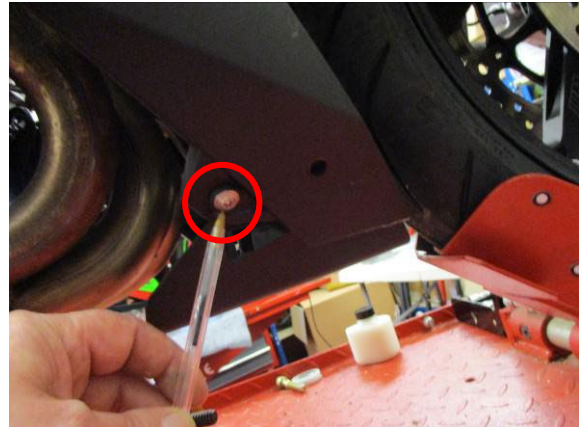

Photo 8

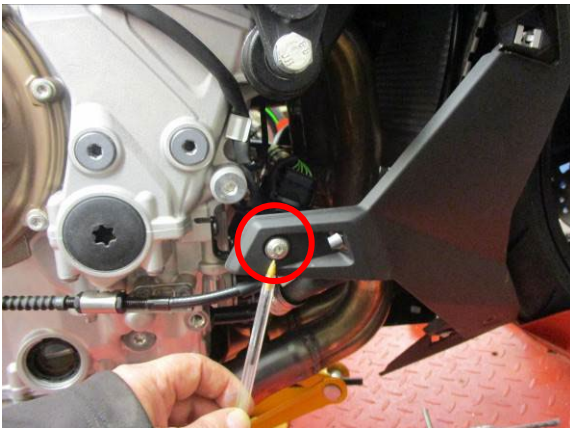

Photo 9

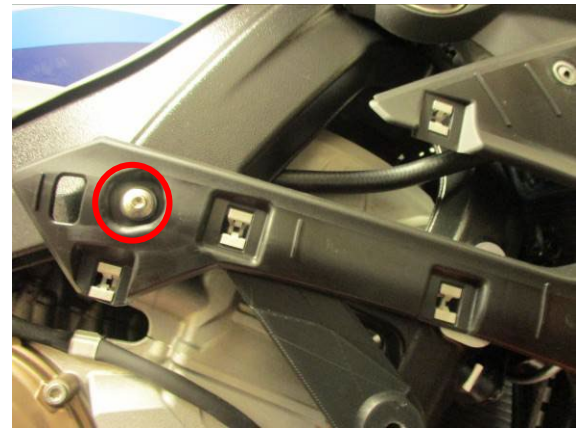

Photo 10



Photo 11



Photo 12



Photo 13

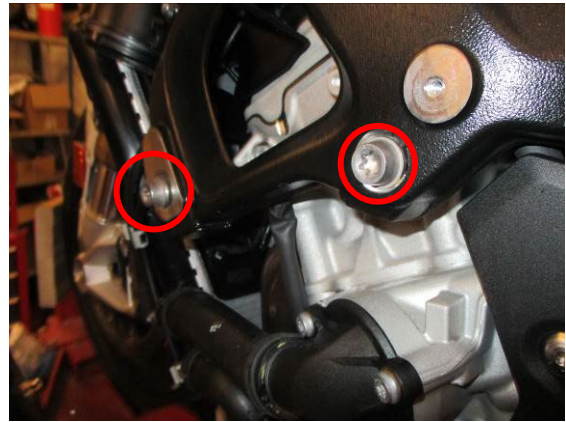

Photo 14



Photo 15

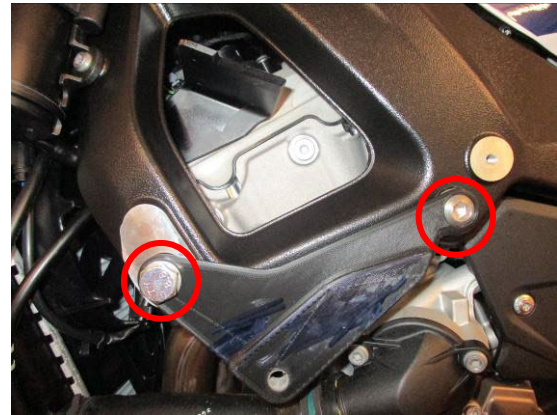

Photo 16

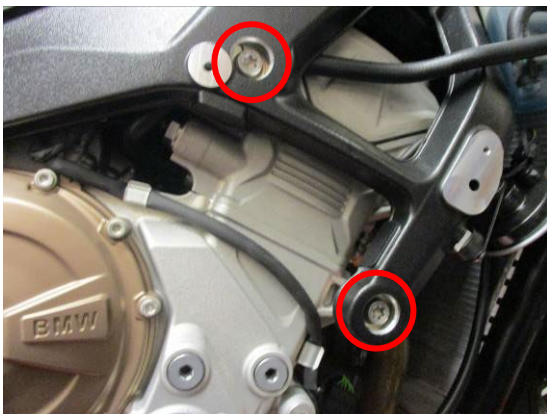

Photo 17

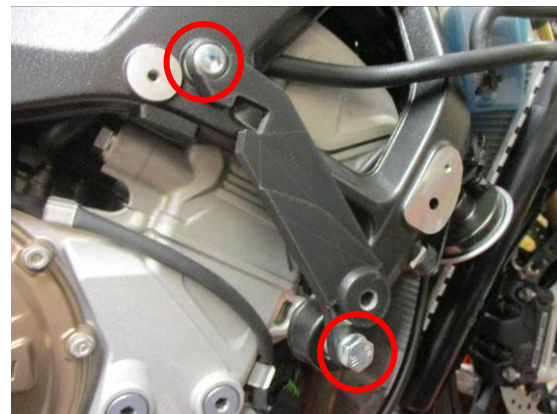

Photo 18



Photo 19



Photo 20



Photo 21



Photo 22



Photo 23



Photo 24



NOTICE DE MONTAGE

AVANT DE RETIRER LES BOULONS DU MOTEUR, ASSUREZ-VOUS QUE LA MOTO SOIT À LA VERTICALE ET SOUTENUE PAR UN SUPPORT DE MOTEUR APPROPRIÉ OU UN CRIC PLACÉ SOUS LE CARTER DE LA MOTO POUR SUPPORTER LE POIDS DU MOTEUR, CELA EMPÊCHERA LE MOTEUR DE SE DÉPLACER PENDANT LE MONTAGE.

ENLEVER LE CARÉNAGE

- Commencez par retirer le couvercle inférieur. Il peut être retiré en retirant la vis illustrée sur la photo 1. Le couvercle blanc doit ensuite être ouvert vers l'extérieur et tiré vers l'arrière comme indiqué sur la photo 2 pour être retiré. Répétez ce processus des deux côtés.
- Ensuite, les couvercles de carénage supérieurs doivent être retirés. Commencez par retirer les 3 vis indiquées sur les photos 3 et 4 des deux côtés.
- Maintenant, la protection peut être retirée doucement. Manipulez le couvercle de manière à ce que les clips sortent un par un jusqu'à ce que le couvercle soit libre et puisse être retiré des deux côtés comme indiqué sur les photos 5, 6 et 7.
- Les pièces de carénage principales doivent maintenant être retirées pour exposer les boulons de montage du kit de protection crash.
- Retirez la vis indiquée sur les photos 8, 9 et 10 des deux côtés.
- Ensuite, le morceau en plastique qui dépasse dans le carénage, près de l'insigne BMW, peut être retiré de l'œillet en caoutchouc des deux côtés, comme indiqué sur la photo 11.
- Enfin, le dernier clip peut être retiré de la partie inférieure du carénage comme indiqué sur la photo 12. Les pièces de carénage restantes peuvent maintenant être retirées des deux côtés.

INSTALLATION DU SUPPORT CÔTÉ GAUCHE

- Avant de retirer les boulons de montage du moteur, assurez-vous que le moteur soit supporté par un cric ou un support moteur comme indiqué sur la photo 13.
- Retirez les 2 boulons indiqués sur la Photo 14.
- Insérez les 2 entretoises (ARTICLE 3) dans les trous laissés par les 2 boulons qui viennent d'être enlevés.
- Présentez le support de montage côté gauche (ARTICLE 1) en position et insérez les 2 boulons (ARTICLES 8 & 9) en position comme indiqué sur la Photo 15.
- Serrez les 2 boulons au couple de serrage spécifié (comme indiqué sur la photo 16) comme indiqué dans le manuel d'entretien BMW.

INSTALLATION DU SUPPORT CÔTÉ DROIT

- Avant de retirer les boulons de montage du moteur, assurez-vous que le moteur soit supporté par un cric ou un support moteur comme indiqué sur la photo 13.
- Retirez les 2 boulons indiqués sur la Photo 17.
- Insérez les 2 entretoises (ARTICLES 4 & 5) dans les trous laissés par les 2 boulons qui viennent d'être enlevés.
- Présentez le support de montage côté droit (ARTICLE 2) en position et insérez les 2 boulons (ARTICLES 8 & 9) en position comme indiqué sur la Photo 18.
- Serrez les 2 boulons au couple de serrage spécifié, comme indiqué dans le manuel d'entretien BMW.

R&G Racing

Unit 1, Shelley's Lane, East Worldham, Alton, Hampshire, GU34 3AQ

Tel: +44 (0)1420 89007 Fax: +44 (0)1420 87301 www.rg-racing.com Email: info@rg-racing.com



INSTALLATION DE LA PROTECTION CRASH

- Avant de fixer les protections crash, réassemblez les carénages sur la moto en inversant les étapes décrites dans la section DÉMONTAGE DU CARÉNAGE. Cela laissera les bossages de montage des bobines comme indiqué sur les photos 19 et 20.
- (Notez qu'une bobine noire a été utilisée du côté gauche et une bobine blanche du côté droit à des fins d'illustration.)
- Insérez les rondelles de blocage (ARTICLE 14), les rondelles plates (ARTICLE 13), puis les vis de protection (ARTICLE 12) dans les bobines et serrez aux bossages comme indiqué sur les photos 21 & 22 à 40Nm.
- Enfin, clipsez les capuchons de protection pour cacher les boulons comme indiqué sur les photos 23 et 24.

ISSUE 1 – 01/02/2022 (WW)

CONSUMER NOTICE

The catalogue description and any exhibition of samples are only broad indications of the Products and R&G may make design changes which do not diminish their performance or visual appeal and supplying them in such state shall conform to the order. The Buyer acknowledges no representation or warranty (other than as to title) has been given or will apply to the Products other than those in R&G's order or confirmation and the Buyer confirms it has chosen the Products as being of merchantable quality and suitable for its particular purposes. Where R&G fits the Products or undertakes other services it shall exercise reasonable skill and care and rectify any fault free of charge unless the workmanship has been disturbed. The Buyer is responsible for ensuring that the warranty on the motorcycle is not affected by the fitting of the Products. On return of any defective Products R&G shall at its option either supply a replacement or refund the purchase money but shall not be liable if the Products have been modified or used or maintained otherwise than in accordance with R&G's or manufacturer's instructions and good engineering practice or if the defect arises from accident or neglect. Other than identified above and subject to R&G not limiting its liability for causing death and personal injury, it shall not be liable for indirect or consequential loss and otherwise its liability shall be limited to the amounts paid by the Buyer for the Products or the fitting or service concerned. These terms do not affect the Buyer's statutory rights.

R&G RACING RETURNS POLICY (NON-FAULTY GOODS)

Returns must be pre-authorized (if not pre-authorized the return will be rejected). Goods may only be returned direct to us if they were purchased direct from us (customer must prove if necessary). Otherwise, to be returned to original vendor. Goods must be in re-sellable condition, in the opinion of R&G Racing. All returns are subject to a 25% restocking and handling fee (25% of the gross value exc. P&P – at the prevailing price at time of purchase). The customer must pay any and all carriage charges. No returns of discontinued products, unless within 14 days of purchase. This policy does not affect your statutory rights and does not refer to faulty goods.

R&G Racing

Unit 1, Shelley's Lane, East Worldham, Alton, Hampshire, GU34 3AQ

Tel: +44 (0)1420 89007 Fax: +44 (0)1420 87301 www.rg-racing.com Email: info@rg-racing.com



MONTAGEANLEITUNG FÜR CP0537 AERO STURZPADS
BMW S1000R (ALLE VERSIONEN) 2021-



ALLE KIT-TEILE SIND AUF DEN NACHFOLGENDEN SEITEN ABGEBILDET UND GEKENNZEICHNET.

DIE ABGEBILDETEN TEILE DIENEN LEDIGLICH ZUR ERKLÄRUNG.

ÜBERPRÜFEN SIE ZUERST, DASS ALLE TEILE VORHANDEN SIND.

LESEN SIE DIE MONTAGEANLEITUNG KOMPLETT DURCH, BEVOR SIE ANFANGEN.

WENN SIE BEI DER MONTAGE DIESES PRODUKTES UNSICHER SIND, BITTE EINEN UNSERER HÄNDLER KONTAKTIEREN ODER DAS KIT VON EINEM QUALIFIZIERTEN ZWEIRAD-MECHANIKER MONTIEREN LASSEN.

DIE VERPACKUNG DER TEILE STELLT NICHT DIE REIHENFOLGE DER MONTAGE DAR.

HINWEIS FÜR KITS MIT PLASTIKUNTERLEGSCHLEIBEN AN DEN SCHRAUBEN –
DIESE PLASTIK-UNTERLEGSCHLEIBEN WERDEN NICHT FÜR DEN EINBAU BENÖTIGT.

EINE DIGITALE VERSION DIESER MONTAGEANLEITUNG KANN AUF FOLGENDER SEITE HERUNTERGELADEN WERDEN:

WWW.RG-RACING.COM

R&G Racing

Unit 1, Shelley's Lane, East Worldham, Alton, Hampshire, GU34 3AQ

Tel: +44 (0)1420 89007 Fax: +44 (0)1420 87301 www.rg-racing.com Email: info@rg-racing.com



<u>SIE BENÖTIGEN FOLGENDES WERKZEUG</u>	<u>ALLGEM. ANZUGSDREHMOMENT</u>
<ul style="list-style-type: none"> • 17mm & 19mm A/F STECKSCHLÜSSEL • 8mm Inbusschlüssel • T45 & T20 Torx-Schlüssel • DREHMOMENTSCHLÜSSEL (BIS 40Nm) • Motorradheber/Montagegeständer 	<p>M4 SCHRAUBE = 8Nm M5 SCHRAUBE = 12Nm M6 SCHRAUBE = 15Nm M8 SCHRAUBE = 20Nm M10 SCHRAUBE = 40Nm M12 SCHRAUBE = 40Nm</p>

LIEFERUMFANG

ARTIKEL NR.	BESCHREIBUNG	MENGE
ARTIKEL 1	M0688 – MONTAGEHALTERUNG LINKE SEITE	1
ARTIKEL 2	M0689 – MONTAGEHALTERUNG RECHTE SEITE	1
ARTIKEL 3	S1396 –DISTANZHALTER HALTER LINKE SEITE	2
ARTIKEL 4	S1397 - DISTANZHALTER HALTER RECHTE SEITE OBEN	1
ARTIKEL 5	S1398 - DISTANZHALTER HALTER RECHTE SEITE UNTEN	1
ARTIKEL 6	B0063 - STURZPAD (BEIDE SEITEN)	2
ARTIKEL 7	BC0002 – STURZPAD-SCHUTZKAPPE	2
ARTIKEL 8	M10x1.50x75mm 8.8 GRAD SECHSKANTSCHRAUBE	2
ARTIKEL 9	BOLT S0008 - M10x1.50x65mm SENKSCHRAUBE	2
ARTIKEL 10	NC0001 - M10 GUMMIKAPPE FÜR MUTTER (BEIDE SEITEN)	2
ARTIKEL 11	NC0009 - M8 FLACHE KUNSTSTOFFKAPPE (BEIDE SEITEN)	2
ARTIKEL 12	M10x1.25x40mm SECHSKANTSCHRAUBE	2
ARTIKEL 13	M10 UNTERLEGSCHEIBE	2
ARTIKEL 14	LW0001 - M12 ZAHNSCHEIBE	2

AERO-STYLE STURZPAD - ORIENTIERUNG

R&G Racing

Unit 1, Shelley's Lane, East Worldham, Alton, Hampshire, GU34 3AQ

Tel: +44 (0)1420 89007 Fax: +44 (0)1420 87301 www.rg-racing.com Email: info@rg-racing.com



ZUSAMMENBAU LINKE SEITE EXPLOSIONSZEICHNUNG

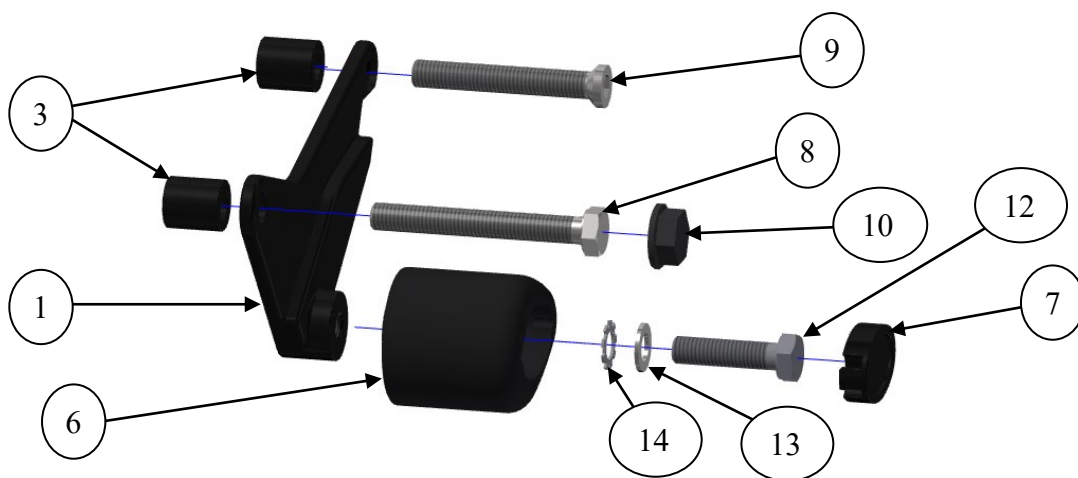

ZUSAMMENBAU RECHTE SEITE EXPLOSIONSZEICHNUNG

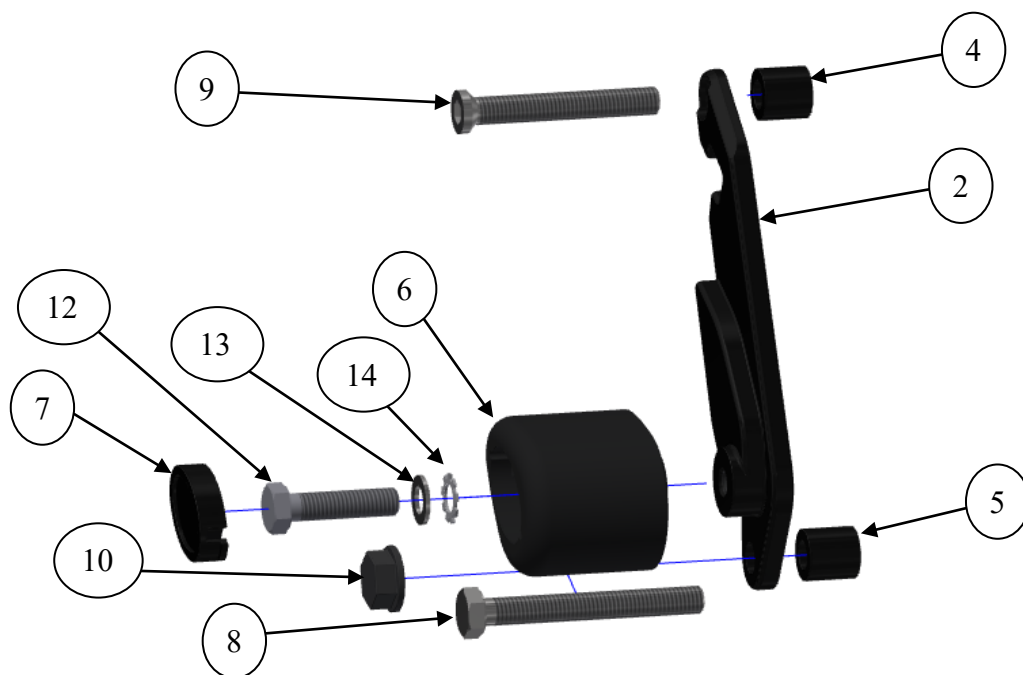



MONTAGE - ABBILDUNGEN



Abbildung 1



Abbildung 2

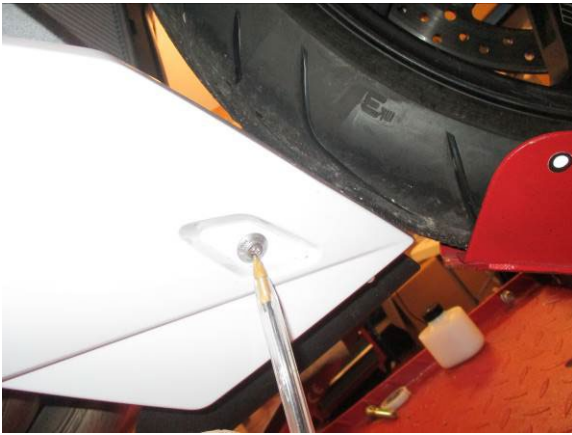

Abbildung 3



Abbildung 4



Abbildung 5



Abbildung 6



Abbildung 7



Abbildung 8



Abbildung 9

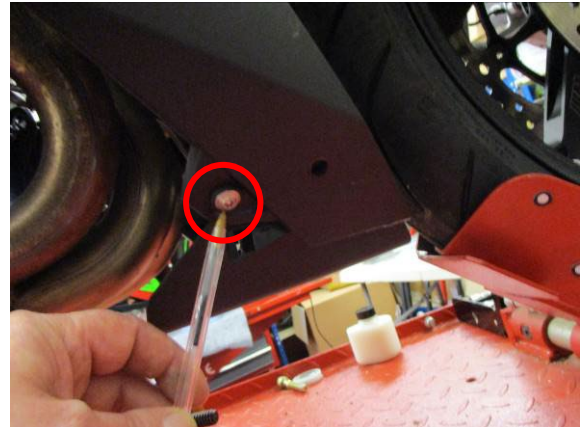

Abbildung 10

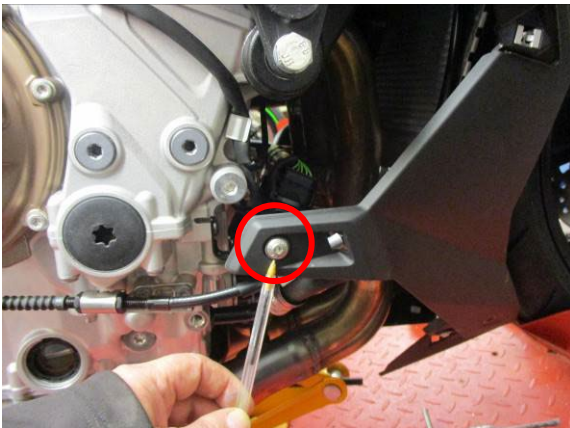

Abbildung 11



Abbildung 12



Abbildung 13



Abbildung 14



Abbildung 15

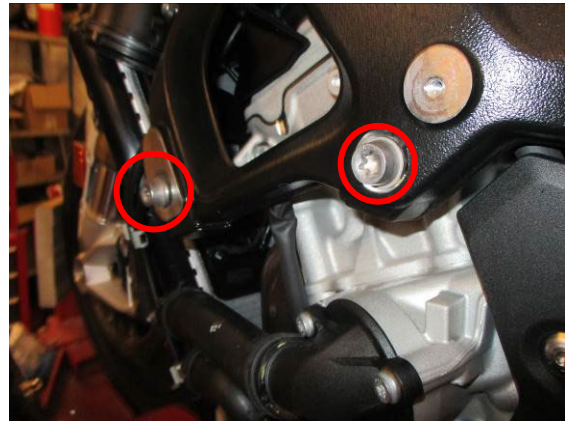

Abbildung 16



Abbildung 17

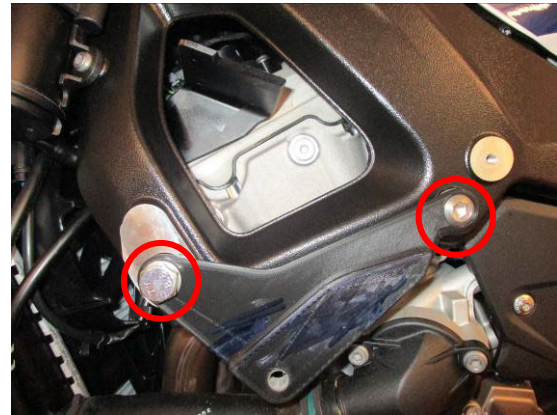

Abbildung 18

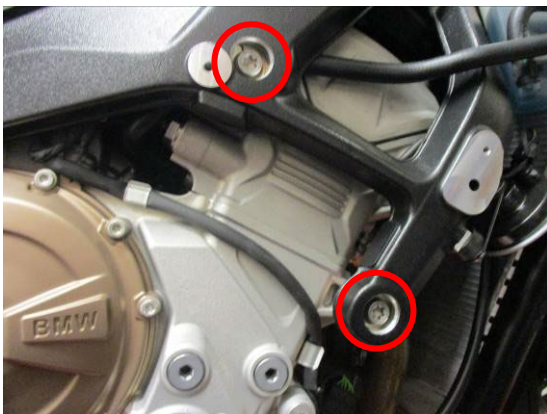

Abbildung 19

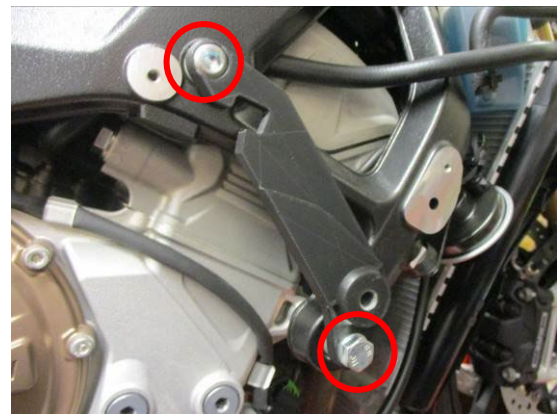

Abbildung 20



Abbildung 21



Abbildung 22



Abbildung 23



Abbildung 24



MONTAGEANLEITUNG

BEVOR SIE DIE SCHRAUBEN FÜR DEN MOTOR ENTFERNEN, STELLEN SIE SICHER, DASS DAS MOTORRAD AUFRECHT STEHT UND DER MOTOR MIT EINEM GEEIGNETEN STÄNDER/HEBER UNTERHALB DER ÖLWANNE GESTÜTZT WIRD. DIES VERHINDERT, DASS DER MOTOR SICH BEI DER ENTFERNUNG VON MOTORSCHRAUBEN BEWEGT.

ABBAU VERKLEIDUNG

- Entfernen Sie zuerst das untere Verkleidungsstück – dies kann abmontiert werden, indem Sie die Schrauben entfernen, die in **Abbildung 1** abgebildet sind. Die weiße Abdeckung muss nach außen herausgedrückt und nach hinten gezogen werden wie in **Abbildung 2** abgebildet. Diesen Vorgang an beiden Seiten wiederholen.
- Als nächstes müssen die oberen Verkleidungsteile abmontiert werden. Entfernen Sie daher an beiden Seiten die 3 Schrauben, die in den **Abbildungen 3 & 4** abgebildet.
- Nun kann das Abdeckteil vorsichtig weggezogen werden. Die Abdeckung bewegen, sodass die Clips sich einzeln lösen bis die Abdeckung frei ist und an beiden Seiten entfernen wie in den **Abbildungen 5, 6 & 7** abgebildet.
- Die Hauptverkleidungsteile sollen nun entfernt werden, um Zugang zu den Montageschrauben für das Sturzpad-Kit zu ermöglichen.
- An beiden Seiten des Motorrads die Schraube entfernt, die in den **Abbildungen 8, 9 & 10** abgebildet ist.
- Als nächstes kann das Vorstehende Kunststoffteil in der Verkleidung (an beiden Seiten in der Nähe des BMW Emblems) von der Gummitülle herausgezogen werden wie in **Abbildung 11** abgebildet.
- Anschließend kann der letzte Clip am unteren Abschnitt der Verkleidung entfernt werden wie in **Abbildung 12** abgebildet. Die übrigen Verkleidungsteile können nun an beiden Seiten entfernt werden.

MONTAGE DER HALTERUNG - LINKE SEITE

- Bevor Sie die Schrauben für den Motor entfernen, stellen Sie sicher, dass der Motor von einem Motorradheber/Montagegeständer gestützt ist wie in **Abbildung 13** abgebildet.
- Entfernen Sie die 2 Schrauben, die in **Abbildung 14** abgebildet sind.
- Die 2 Distanzhalter (ARTIKEL 3) nun in die Öffnungen einsetzen, die durch die Entfernung der Schrauben entstanden sind.
- Die Montagehalterung für die linke Seite (ARTIKEL 1) in Position bringen und die 2 Schrauben (ARTIKEL 8 & 9) einsetzen wie in **Abbildung 15** in abgebildet.
- Ziehen Sie die 2 Schrauben mit dem vom Hersteller empfohlenen Anzugsdrehmoment fest (wie in **Abbildung 16** abgebildet) – siehe BMW-Bedienerhandbuch.

MONTAGE DER HALTERUNG – RECHTE SEITE

- Bevor Sie die Schrauben für den Motor entfernen, stellen Sie sicher, dass der Motor von einem Motorradheber/Montagegeständer gestützt ist wie in **Abbildung 13** abgebildet.
- Entfernen Sie die 2 Schrauben, die in **Abbildung 17** abgebildet sind.
- Die 2 Distanzhalter (ARTIKEL 4 & 5) nun in die Öffnungen einsetzen, die durch die Entfernung der Schrauben entstanden sind.
- Die Montagehalterung für die rechte Seite (ARTIKEL 2) in Position bringen und die 2 Schrauben (ARTIKEL 8 & 9) einsetzen wie **Abbildung 18** in abgebildet.
- Ziehen Sie die 2 Schrauben mit dem vom Hersteller spezifizierten Anzugsdrehmoment fest (siehe BMW-Bedienerhandbuch).

R&G Racing

Unit 1, Shelley's Lane, East Worldham, Alton, Hampshire, GU34 3AQ

Tel: +44 (0)1420 89007 Fax: +44 (0)1420 87301 www.rg-racing.com Email: info@rg-racing.com



MONTAGE DER STURZPADS

- Bevor Sie die Sturzpads anbauen, montieren Sie die zuvor entfernten Verkleidungsteile wieder (die Schritte im Abschnitt ABBAU VERKLEIDUNG in umgekehrter Reihenfolge ausführen). Die Montageöffnungen sind anschließend noch zugänglich – siehe **Abbildungen 19 & 20**.
- (Hinweis: Aus Darstellungszwecken ist ein schwarzes Sturzpad für die linke Seite benutzt worden und ein weißes Sturzpad für die rechte Seite.)
- Die Zahnscheiben (ARTIKEL 14), Unterlegscheiben (ARTIKEL 13) und anschließend die Schrauben für die Sturzpads (ARTIKEL 12) in die Sturzpads einsetzen und mit 40 Nm befestigen wie in den **Abbildungen 21 & 22** abgebildet.
- Montieren Sie die Schutzkappen, um die Schraubenköpfe abzudecken -siehe **Abbildungen 23 & 24**.

AUSGABE 1 – 01/02/2022 (WW)

CONSUMER NOTICE

The catalogue description and any exhibition of samples are only broad indications of the Products and R&G may make design changes which do not diminish their performance or visual appeal and supplying them in such state shall conform to the order. The Buyer acknowledges no representation or warranty (other than as to title) has been given or will apply to the Products other than those in R&G's order or confirmation and the Buyer confirms it has chosen the Products as being of merchantable quality and suitable for its particular purposes. Where R&G fits the Products or undertakes other services it shall exercise reasonable skill and care and rectify any fault free of charge unless the workmanship has been disturbed. The Buyer is responsible for ensuring that the warranty on the motorcycle is not affected by the fitting of the Products. On return of any defective Products R&G shall at its option either supply a replacement or refund the purchase money but shall not be liable if the Products have been modified or used or maintained otherwise than in accordance with R&G's or manufacturer's instructions and good engineering practice or if the defect arises from accident or neglect. Other than identified above and subject to R&G not limiting its liability for causing death and personal injury, it shall not be liable for indirect or consequential loss and otherwise its liability shall be limited to the amounts paid by the Buyer for the Products or the fitting or service concerned. These terms do not affect the Buyer's statutory rights.

R&G RACING RETURNS POLICY (NON-FAULTY GOODS)

Returns must be pre-authorized (if not pre-authorized the return will be rejected). Goods may only be returned direct to us if they were purchased direct from us (customer must prove if necessary). Otherwise, to be returned to original vendor. Goods must be in re-sellable condition, in the opinion of R&G Racing. All returns are subject to a 25% restocking and handling fee (25% of the gross value exc. P&P – at the prevailing price at time of purchase). The customer must pay any and all carriage charges. No returns of discontinued products, unless within 14 days of purchase. This policy does not affect your statutory rights and does not refer to faulty goods.

R&G Racing

Unit 1, Shelley's Lane, East Worldham, Alton, Hampshire, GU34 3AQ

Tel: +44 (0)1420 89007 Fax: +44 (0)1420 87301 www.rg-racing.com Email: info@rg-racing.com