



FITTING INSTRUCTIONS FOR CG0018 CHAIN GUARD
YAMAHA TRACER 900GT 2018-

Page | 1



THIS KIT CONTAINS THE ITEMS PICTURED AND LABELLED BELOW.
DO NOT PROCEED UNTIL YOU ARE SURE ALL PARTS ARE PRESENT.

Please note that the way the kit is packed does not necessarily represent the way of mounting to the bike

THE PARTS SHOWN MAY BE REPRESENTATIVE ONLY (FOR CLARITY OF INSTRUCTIONS ONLY)

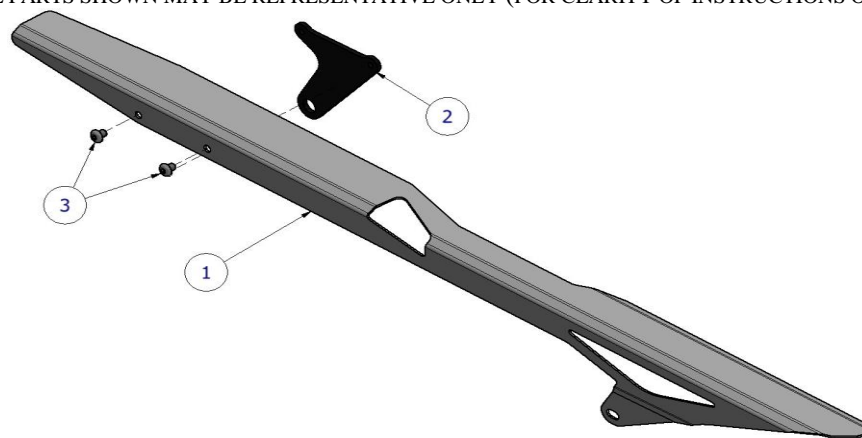

LEGEND

ITEM 1= CHAIN GUARD (SMW0127) (x1).

ITEM 2= CHAIN GUARD SUPPORT PLATE (PLATE 0098) (x1).

ITEM 3= M5x6mm LONG BUTTON HEAD BOLTS (x2).

TOOLS REQUIRED

- Metric socket set and wrench.

R&G

Unit 1, Shelley's Lane, East Worldham, Alton, Hampshire, GU34 3AQ

Tel: +44 (0)1420 89007 Fax: +44 (0)1420 87301 www.rg-racing.com Email: info@rg-racing.com

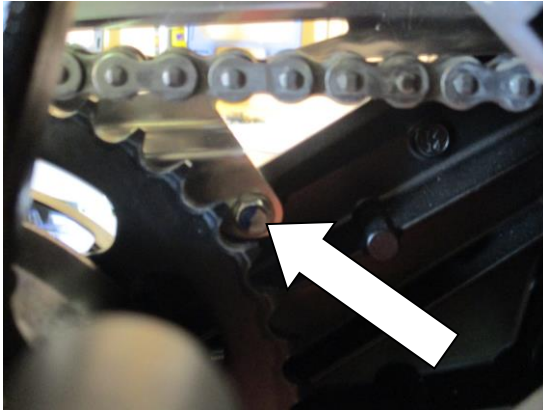

Picture 1



Picture 2



Picture 3



Picture 4



Picture 5

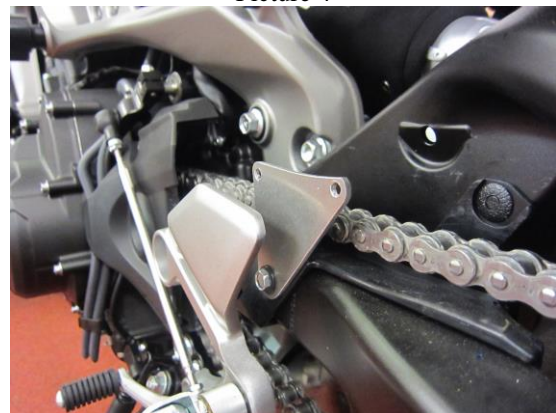

Picture 6



Picture 7



Picture 8

INSTRUCTIONS

- *Please note - Fitting the chain guard is easier if the rear wheel is removed, although it is possible to fit it with the rear wheel in place. If removing the rear wheel, remove the large nut on the right side of the rear wheel axle, remove the axle, lift the chain off the sprocket and gently pull the rear wheel clear.*
- Remove the bolt on the inside of the swingarm which attaches the rear of the OEM plastic chain guard in place, as arrowed in picture 1. If the rear wheel is not removed it is possible to roll the wheel and sprocket into a position where the bolt can be removed using a socket and extension. *There will be a metal top hat spacer fitted into the plastic. This will NOT be required for fitting the R&G chain guard.*
- Remove the bolt that attaches the front of the OEM plastic chain guard to the swingarm, located behind the foot rest heel plate, as shown in picture 2. *The metal top hat which is fitted into the plastic here WILL be required when fitting the R&G chain guard.*
- There is also an additional push rivet which attaches the OEM plastic chain guard to the front of the swingarm. This needs to be removed and is positioned behind the chain line and in front of the swingarm cross brace, as shown in picture 3.
- The OEM plastic chain guard can now be removed from the bike. To do this, gently slide it out toward the rear of the bike. *It may require a bit of twisting and is easier with the rear wheel removed.*
- Now take the small metal plate supplied and the top hat spacer removed from the front mounting point of the OEM plastic chain guard and fit it into the largest hole on the metal plate, ensuring it is located from the correct side, as shown in picture 5. *When looking at the front of the plate, it should look like a "y" with the spacer fitted from this side.*
- Fit this onto the front mount on the swingarm, before refitting the original bolt and loosely tighten in place, as shown in picture 6.
- From the rear of the bike, slide the main part of the R&G chain guard into place, through the open area of the swingarm and locate into place over the pre-fitted front mounting plate, as shown in picture 7.
- Fit the two M5 x 6mm long button head bolts through the stainless chain guard and into the threaded holes in the metal plate, before loosely tightening, as shown in picture 8.
- The rear of the chain guard can now be aligned with the threaded hole on the inside of the swingarm. Re-fit the original bolt and tighten.
- Tighten the three bolts at the front of the chain guard and ensure the chain guard is correctly fitted.
- *If removed, re-fit the rear wheel.*
- Please ensure the chain will not hit the chain guard in operation.

R&G



Issue 1 13/08/2018 (HB)

Digital copies of these instructions are available to download from www.rg-racing.com

Page | 4

CONSUMER NOTICE

The catalogue description and any exhibition of samples are only broad indications of the Products and R&G may make design changes which do not diminish their performance or visual appeal and supplying them in such state shall conform to the order. The Buyer acknowledges no representation or warranty (other than as to title) has been given or will apply to the Products other than those in R&G's order or confirmation and the Buyer confirms it has chosen the Products as being of merchantable quality and suitable for its particular purposes. Where R&G fits the Products or undertakes other services it shall exercise reasonable skill and care and rectify any fault free of charge unless the workmanship has been disturbed. The Buyer is responsible for ensuring that the warranty on the motorcycle is not affected by the fitting of the Products. On return of any defective Products R&G shall at its option either supply a replacement or refund the purchase money but shall not be liable if the Products have been modified or used or maintained otherwise than in accordance with R&G's or manufacturer's instructions and good engineering practice or if the defect arises from accident or neglect. Other than identified above and subject to R&G not limiting its liability for causing death and personal injury, it shall not be liable for indirect or consequential loss and otherwise its liability shall be limited to the amounts paid by the Buyer for the Products or the fitting or service concerned. These terms do not affect the Buyer's statutory rights.

R&G RETURNS POLICY (NON-FAULTY GOODS)

Returns must be pre-authorized (if not pre-authorized the return will be rejected). Goods may only be returned direct to us if they were purchased direct from us (customer must prove if necessary). Otherwise to be returned to original vendor. Goods must be in resellable condition, in the opinion of R&G. All returns are subject to a 25% restocking and handling fee (25% of the gross value exc. P&P – at the prevailing price at time of purchase). The customer must pay any and all carriage charges. No returns of discontinued products, unless within 14 days of purchase. This policy does not affect your statutory rights and does not refer to faulty goods.

R&G

Unit 1, Shelley's Lane, East Worldham, Alton, Hampshire, GU34 3AQ
Tel: +44 (0)1420 89007 Fax: +44 (0)1420 87301 www.rg-racing.com Email: info@rg-racing.com



NOTICE DE MONTAGE POUR CG0018 PROTECTION CHAÎNE
YAMAHA TRACER 900GT 2018-

Page | 5



Le kit contient les articles exposés ci-dessous, vérifier que toutes les pièces soient présentes avant de procéder au montage.

La façon dont le kit est emballé ne correspond pas forcément à la façon de monter les pièces sur la moto.

LES PARTIES PRÉSENTÉES PEUVENT ÊTRE UNIQUEMENT REPRESENTATIVES (POUR LA CLARTE DES INSTRUCTIONS UNIQUEMENT)

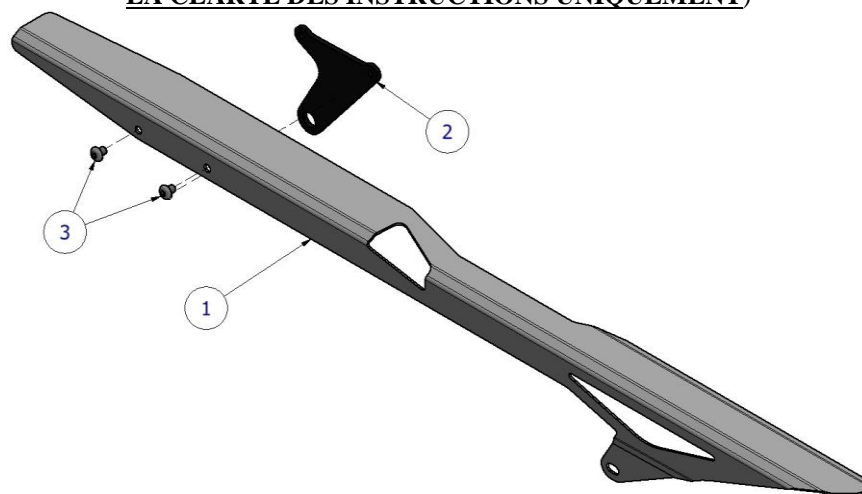

R&G

Unit 1, Shelley's Lane, East Worldham, Alton, Hampshire, GU34 3AQ
 Tel: +44 (0)1420 89007 Fax: +44 (0)1420 87301 www.rg-racing.com Email: info@rg-racing.com



LÉGENDE

ARTICLE 1= PROTECTION CHAÎNE (SMW0127) (x1).

ARTICLE 2= PLAQUE DE SUPPORT DE PROTECTION CHAÎNE (PLAQUE 0098) (x1).

ARTICLE 3= M5x6mm BOULONS (x2).

Page | 6

OUTILS REQUIS

- Clé à cliquet + douilles.

NOTICE DE MONTAGE

- *Note : Il est plus facile de monter la protection chaîne si la roue arrière est enlevée, cependant il est possible de monter la protection avec la roue arrière en place. Si vous retirez la roue arrière, enlevez l'écrou du côté droit du moyeu de roue arrière, enlevez le moyeu, soulevez la chaîne du pignon puis retirez la roue arrière.*
- Enlever le boulon à l'intérieur du bras oscillant qui attache l'arrière de la protection chaîne d'origine en place, voir photo 1. Si la roue arrière n'est pas enlevée, il est possible de rouler la roue et le pignon en position à l'endroit où le boulon peut être enlevé, en utilisant une clé et une extension. *Il y a une entretoise située dans le plastique. Elle ne sera pas nécessaire lors du montage de la protection R&G.*
- *Retirez le boulon qui attache l'avant de la protection de chaîne en plastique d'origine au bras oscillant, situé derrière la plaque de talon du repose-pied, voir la photo 2. Le chapeau supérieur métallique qui est monté dans le plastique sera nécessaire lors du montage de la protection chaîne R&G.*
- Il y a aussi un rivet qui attache le protège-chaîne en plastique d'origine à l'avant du bras oscillant. Il doit être enlevé et être placé derrière la ligne de la chaîne et en face de la traverse de bras oscillant, voir la photo 3.
- Le protège-chaîne en plastique d'origine peut maintenant être retiré de la moto. Pour ce faire, faites-le glisser doucement vers l'arrière de la moto. Cette opération peut nécessiter un peu de torsion, ce qui est plus facile si la roue arrière est retirée.
- Maintenant, retirez la petite plaque de métal fournie et l'entretoise supérieure du point de montage avant du protège-chaîne en plastique d'origine puis placez-la dans le plus grand trou de la plaque métallique, en vous assurant qu'elle se trouve du bon côté, comme illustré sur la photo 5. Lorsque vous regardez l'avant de la plaque, cela devrait ressembler à un "y" avec l'entretoise montée de ce côté.
- Placez-la sur le support avant du bras oscillant, avant de remettre en place le boulon d'origine et de le serrer légèrement, voir la photo 6.
- Depuis l'arrière de la moto, faites glisser la partie principale du protège-chaîne R&G à travers la zone ouverte du bras oscillant puis placez-le sur la plaque de montage avant préinstallée, voir la photo 7.
- Insérer les 2 boulons M5 x 6mm dans le protège chaîne puis dans les trous filetés de la plaque métallique, avant de serrer légèrement, voir photo 8.
- L'arrière du protège-chaîne peut maintenant être aligné avec le trou fileté à l'intérieur du bras oscillant. Remettez le boulon d'origine et serrez.
- Serrer les trois boulons à l'avant du protège-chaîne et s'assurer que le protège-chaîne soit correctement monté.
- En cas de retrait, remontez la roue arrière.
- Veuillez-vous assurer que la chaîne ne heurtera pas le protège-chaîne en fonctionnement

R&G

Unit 1, Shelley's Lane, East Worldham, Alton, Hampshire, GU34 3AQ

Tel: +44 (0)1420 89007 Fax: +44 (0)1420 87301 www.rg-racing.com Email: info@rg-racing.com



Issue 1 13/08/2018 (HB)

Notice disponible au téléchargement sur www.rg-racing.com

Page | 7

CONSUMER NOTICE

The catalogue description and any exhibition of samples are only broad indications of the Products and R&G may make design changes which do not diminish their performance or visual appeal and supplying them in such state shall conform to the order. The Buyer acknowledges no representation or warranty (other than as to title) has been given or will apply to the Products other than those in R&G's order or confirmation and the Buyer confirms it has chosen the Products as being of merchantable quality and suitable for its particular purposes. Where R&G fits the Products or undertakes other services it shall exercise reasonable skill and care and rectify any fault free of charge unless the workmanship has been disturbed. The Buyer is responsible for ensuring that the warranty on the motorcycle is not affected by the fitting of the Products. On return of any defective Products R&G shall at its option either supply a replacement or refund the purchase money but shall not be liable if the Products have been modified or used or maintained otherwise than in accordance with R&G's or manufacturer's instructions and good engineering practice or if the defect arises from accident or neglect. Other than identified above and subject to R&G not limiting its liability for causing death and personal injury, it shall not be liable for indirect or consequential loss and otherwise its liability shall be limited to the amounts paid by the Buyer for the Products or the fitting or service concerned. These terms do not affect the Buyer's statutory rights.

R&G RETURNS POLICY (NON-FAULTY GOODS)

Returns must be pre-authorized (if not pre-authorized the return will be rejected). Goods may only be returned direct to us if they were purchased direct from us (customer must prove if necessary). Otherwise to be returned to original vendor. Goods must be in resellable condition, in the opinion of R&G. All returns are subject to a 25% restocking and handling fee (25% of the gross value exc. P&P – at the prevailing price at time of purchase). The customer must pay any and all carriage charges. No returns of discontinued products, unless within 14 days of purchase. This policy does not affect your statutory rights and does no

R&G

Unit 1, Shelley's Lane, East Worldham, Alton, Hampshire, GU34 3AQ
Tel: +44 (0)1420 89007 Fax: +44 (0)1420 87301 www.rg-racing.com Email: info@rg-racing.com



**MONTAGEANLEITUNG FÜR CG0018 KETTENSCHUTZ
YAMAHA TRACER 900GT 2018-**

Page | 8



ALLE TEILE SIND UNTEN ABGEBILDET UND GEKENNZEICHNET. BEVOR SIE MIT DER MONTAGE BEGINNEN, ÜBERPRÜFEN SIE, DASS ALLE TEILE VORHANDEN SIND.

Hinweis: Die Verpackung der Teile stellt nicht die Reihenfolge der Montage dar.

DIE UNTEN ABGEBILDETEN TEILE DIENEN LEDIGLICH ZUR ERKLÄRUNG

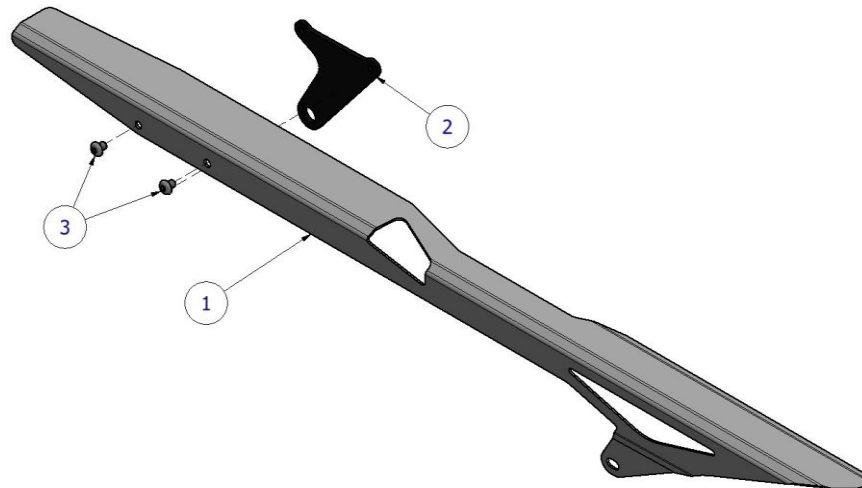

LIEFERUMFANG

ARTIKEL 1= KETTENSCHUTZ (SMW0127) (x1)

ARTIKEL 2= HALTEPLATTE FÜR DEN KETTENSCHUTZ (PLATE 0098) (x1)

ARTIKEL 3= M5x6mm INBUSSCHRAUBEN (x2)

R&G

Unit 1, Shelley's Lane, East Worldham, Alton, Hampshire, GU34 3AQ
Tel: +44 (0)1420 89007 Fax: +44 (0)1420 87301 www.rg-racing.com Email: info@rg-racing.com



SIE BENÖTIGEN FOLGENDES WERKZEUG

- Satz Steckschlüssel und Sechskantschlüssel

MONTAGEANLEITUNG

Page | 9

- *Hinweis – Der Kettenschutz kann montieren werden, wenn das Hinterrad noch eingebaut ist. Die Montage ist jedoch viel einfacher, wenn das Hinterrad abmontiert ist. Wenn Sie das Hinterrad ausbauen, entfernen Sie die große Mutter an der rechten Seite der Hinterradachse, die Achse entfernen und die Kette aus dem Zahnrad heben und das Hinterrad vorsichtig vom Motorrad entfernen.*
- Entfernen Sie die Schraube an der Innenseite der Swinge, die den original Kettenschutz aus Plastik befestigt – siehe Abbildung 1. Wenn das Hinterrad nicht abmontiert wurde, ist es möglich, das Rad und das Kettenrad in eine passende Position zu drehen, wo die Schraube mit einem Steckschlüssel mit Verlängerung entfernt werden kann. Ein „Top-Hat“- Distanzhalter aus Metall ist im Kunststoff fixiert – dieser Distanzhalter wird NICHT bei der Montage des R&G Kettenschutz benötigt.
- Entfernen Sie die Schraube, die den original Kettenschutz vorne an der Schwinge befestigt (hinter der Platte an der Fußraste – siehe Abbildung 2). Der „Top-Hat“- Distanzhalter aus Metall ist im Kunststoff fixiert – dieser Distanzhalter WIRD bei der Montage des R&G Kettenschutz benötigt.
- Die zusätzliche Plastikniete, die den original Kettenschutz vorne an der Schwinge fixiert muss entfernt werden. Die Niete ist vor der Querstrebe an der Schwinge positioniert – siehe Abbildung 3.
- Der original Kettenschutz aus Kunststoff kann nun vom Motorrad entfernt werden. Den Kettenschutz vorsichtig nach hinten schieben. *Es ist eventuell notwendig, den Kettenschutz hierbei etwas zu drehen – es ist jedoch einfacher, wenn das Hinterrad abgebaut ist.*
- Nehmen Sie jetzt die kleine Metallplatte vom Kit und den bereits entfernten Hut-Distanzhalter, der vom vorderen Montagepunkt des original Kettenschutzes entfernt wurde. Montieren Sie den Distanzhalter in der größten Öffnung an der Metallplatte – bitte darauf achten, dass er an der richtigen Seite fixiert wird – siehe Abbildung 5. *Wenn Sie die Platte vorne anschauen, sollte sie wie ein „y“ aussehen mit dem Distanzhalter von der Seite montiert.*
- Montieren Sie das an der vorderen Halterung der Schwinge, bevor Sie die Originalschraube wieder montieren und lose in Position befestigen – siehe Abbildung 6.
- Von der Rückseite des Motorrads beginnend, schieben Sie den Hauptteil des R&G Kettenschutz in Position, durch den offenen Bereich der Schwinge und über die bereits montierte vordere Montageplatte legen – siehe Abbildung 7.
- Montieren Sie die zwei M5 x 6mm Inbusschrauben durch den rostfreien Kettenschutz in die Gewindebohrungen an der Metallplatte, bevor Sie sie lose befestigen – siehe Abbildung 8.
- Der Kettenschutz hinten kann nun mit der Gewindeöffnung an der Innenseite der Schwinge ausgerichtet werden.
- Montieren / befestigen Sie die Originalschraube wieder.
- Ziehen Sie die drei Schrauben vorne am Kettenschutz fest und überprüfen Sie, dass der Kettenschutz ordnungsgemäß montiert ist.
- *Falls zuvor abmontiert, montieren Sie das Hinterrad wieder.*
- Bitte sicherstellen, dass der Kettenschutz nicht von der Kette berührt wird, wenn das Motorrad in Betrieb ist.

Ausgabe 1 13/08/2018 (HB)

R&G

Unit 1, Shelley's Lane, East Worldham, Alton, Hampshire, GU34 3AQ
 Tel: +44 (0)1420 89007 Fax: +44 (0)1420 87301 www.rg-racing.com Email: info@rg-racing.com



Eine digitale Version dieser Montageanleitung kann auf folgender Seite heruntergeladen werden:

www.rg-racing.com

CONSUMER NOTICE

The catalogue description and any exhibition of samples are only broad indications of the Products and R&G may make design changes which do not diminish their performance or visual appeal and supplying them in such state shall conform to the order. The Buyer acknowledges no representation or warranty (other than as to title) has been given or will apply to the Products other than those in R&G's order or confirmation and the Buyer confirms it has chosen the Products as being of merchantable quality and suitable for its particular purposes. Where R&G fits the Products or undertakes other services it shall exercise reasonable skill and care and rectify any fault free of charge unless the workmanship has been disturbed. The Buyer is responsible for ensuring that the warranty on the motorcycle is not affected by the fitting of the Products. On return of any defective Products R&G shall at its option either supply a replacement or refund the purchase money but shall not be liable if the Products have been modified or used or maintained otherwise than in accordance with R&G's or manufacturer's instructions and good engineering practice or if the defect arises from accident or neglect. Other than identified above and subject to R&G not limiting its liability for causing death and personal injury, it shall not be liable for indirect or consequential loss and otherwise its liability shall be limited to the amounts paid by the Buyer for the Products or the fitting or service concerned. These terms do not affect the Buyer's statutory rights.

R&G RETURNS POLICY (NON-FAULTY GOODS)

Returns must be pre-authorized (if not pre-authorized the return will be rejected). Goods may only be returned direct to us if they were purchased direct from us (customer must prove if necessary). Otherwise to be returned to original vendor. Goods must be in re-sellable condition, in the opinion of R&G. All returns are subject to a 25% restocking and handling fee (25% of the gross value exc. P&P – at the prevailing price at time of purchase). The customer must pay any and all carriage charges. No returns of discontinued products, unless within 14 days of purchase. This policy does not affect your statutory rights and does not refer to faulty goods.